



Attached are page(s) from the 2011 Hilti North American Product Technical Guide. For complete details on this product, including data development, product specifications, general suitability, installation, corrosion, and spacing & edge distance guidelines, please refer to the Technical Guide, or contact Hilti.

KWIK Bolt 3 Expansion Anchor 3.3.6

3.3.6.1 Product Description

The KWIK Bolt 3 (KB3) is a torque controlled expansion anchor, which provides consistent performance for a wide range of mechanical anchor applications. This anchor series is available in carbon steel with zinc electroplated coating, carbon steel with hot-dip galvanized coating, 304 stainless steel and 316 stainless steel versions. The threaded stud version of the anchor is available in a variety of diameters ranging from 1/4-in. to 1-in. depending on the steel and coating type. Applicable base materials include normal-weight concrete, structural lightweight concrete, lightweight concrete over metal deck, and grout filled concrete masonry.

Guide Specifications

Torque controlled expansion anchors shall be KWIK Bolt 3 supplied by Hilti meeting the description in Federal Specification A-A 1923A, Type 4. The anchor bears a length identification mark embossed into the impact section (dog point) of the anchor identifying the anchor as a Hilti KWIK Bolt 3 in the installed condition. Anchors are manufactured to meet one of the following conditions:

1. The carbon steel anchor body, nut and washer have an electroplated zinc coating conforming to ASTM B 633 to a minimum thickness of 5 µm.
2. The carbon steel hot-dip galvanized anchor body, nut, and washer conform to ASTM A 153. The stainless steel expansion elements conform to either type 304 or type 316.
3. The stainless steel anchor body, nut, and washer conform to type 304. The stainless steel expansion elements conform to either type 304 or type 316.
4. The stainless steel anchor body, nut, and washer conform to type 316. The stainless steel expansion elements conform to type 316.

Product Features

- Length identification code facilitates quality control and inspection after installation.
- Through fixture installation and variable thread lengths improve productivity and accommodate various base plate thicknesses.
- Raised impact section (Dog Point) prevents thread damage during installation.
- Anchor size is same as drill bit size for easy installation. For temporary applications anchors may be driven into drilled holes after usage.
- Mechanical expansion allows immediate load application.

Installation

Drill hole in concrete, structural lightweight concrete, or grout filled concrete masonry using a Hilti carbide tipped drill bit and a Hilti rotary hammer drill. Remove dust from the hole with oil free compressed air or vacuum. Alternately for 1/2-, 5/8-, 3/4- and 1-inch diameter KWIK Bolt 3 anchors, the hole may be drilled using a matched tolerance Hilti DD-C wet diamond core bit for anchoring applications. The slurry must be flushed from the diamond cored hole prior to anchor installation. The minimum hole depth must exceed the anchor embedment prior to torquing by at least by one hole diameter. Drive the anchor into the hole using a hammer. A minimum of six threads must be below the surface of the fixture. Tighten the nut to the installation torque.

3.3.6.1	Product Description
3.3.6.2	Material Specifications
3.3.6.3	Strength Design (LRFD)
3.3.6.4	Allowable Stress Design (ASD)
3.3.6.5	Installation Instructions
3.3.6.6	Ordering Information

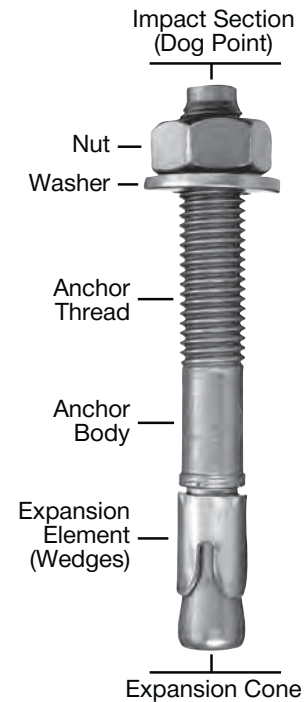

Listings/Approvals

ICC-ES (International Code Council)
ESR-2302
ICC-ES ESR-1385
Grout filled concrete masonry
City of Los Angeles
Research Report No. 25577
Research Report No. 25577M
for masonry
FM (Factory Mutual)
Pipe Hanger Components for
Automatic Sprinkler (3/8" - 3/4")
UL (Underwriters Laboratories)
UL 203 Pipe Hanger Equipment for Fire
Protection Services (3/8" - 3/4")
Miami-Dade County
NOA No. 06-0810.13
Qualified under an NQA-1 Nuclear
Quality Program



*Please refer to the reports to verify that the type and diameter specified is included

Independent Code Evaluation

IBC® / IRC® 2009
(AC 193 / ACI 355.2, AC 01)
IBC® / IRC® 2006
(AC 193 / ACI 355.2, AC 01)
IBC® / IRC® 2003
(AC 193 / ACI 355.2)

3.3.6 KWIK Bolt 3 Expansion Anchor

3.3.6.2 Material Properties

Carbon Steel with Electroplated Zinc

All Carbon Steel KWIK Bolt 3 and Rod Coupling Anchors, excluding the 3/4 x 12 and 1-inch diameter sizes, have the tensile bolt fracture loads shown in Table 5.

All carbon steel 3/4 x 12 and 1 inch diameter sizes and carbon steel countersunk KWIK Bolt 3 anchor bodies have mechanical properties as listed in Table 5.

Carbon steel anchor components plated in accordance with ASTM B633 to a minimum thickness of 5 µm.

Nuts conform to the requirements of ASTM A 563, Grade A, Hex.

Washers meet the requirements of ASTM F 844.

Expansion elements (wedges) are manufactured from carbon steel, except the following anchors have stainless steel wedges:

- All 1/4-inch diameter anchors
 - KB3 3/4x12
 - All 1-inch diameter anchors
 - All countersunk KWIK Bolt 3
-

Carbon Steel with Hot-Dip Galvanized Coating

Anchor bodies manufactured from carbon steel have the tensile bolt fracture loads shown in Table 5.

Carbon steel anchor components hot-dip galvanized according to ASTM A 153, Class C (43 µm min.).

Nuts conform to the requirements of ASTM A 563, Grade A, Hex.

Washers meet the requirements of ASTM F 844.

Stainless steel expansion elements (wedges) are manufactured from either type 304 or type 316.

Stainless Steel

Anchor bodies smaller than 3/4-inch, excluding all Countersunk KWIK Bolt 3 anchors, are produced from type 304 or type 316 stainless steel having the bolt fracture loads shown in Table 5.

Anchor bodies 3/4-inch and larger, and all stainless steel Countersunk KWIK Bolt 3 anchor bodies, are produced from AISI 304 or 316 stainless steel having the mechanical properties shown in Table 5.

Nuts meet the dimensional requirements of ASTM F 594.

Washers meet the dimensional requirements of ANSI B18.22.1, Type A, plain.

Stainless steel expansion elements for type 304 anchors are made from either type 304 or type 316. Stainless steel expansion elements for type 316 anchors are made from type 316. All stainless steel nuts and washers for type 304 and type 316 anchors are manufactured from type 304 and type 316, respectively.

KWIK Bolt 3 Expansion Anchor 3.3.6

3.3.6.3 Strength Design (LRFD)

This section provides ACI 318 strength design information for the KWIK Bolt 3 used where the required post-installed anchor design must comply with the IBC 2003, IBC 2006 and IBC 2009. Testing was conducted in accordance with ACI 355.2 and ICC-ES AC193 in uncracked concrete. Engineering design based on this section is limited to uncracked concrete and seismic design categories A & B.

For more detailed information, please contact Hilti Technical Support. Note that the allowable load tables are not developed using the same safety factors as the allowable load Table 6 to 15 provided in the allowable load Section 4.3.5.4 of the 2008 Product Technical Guide and should not be interchanged. Edge distance and anchor spacing guidelines are specific for each design method. The installation torques for the 5/8-, 3/4- and 1-inch diameter anchors have been reduced in order to maintain reasonable spacing guidelines as developed in accordance with ACI 355.2.

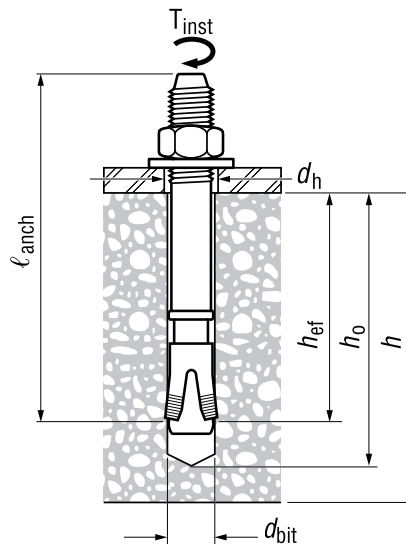

Figure 1 - KWIK Bolt 3 Installation

Table 1 - Installation Information Strength Design

Setting Information	Symbol	Units	Nominal anchor diameter									
			1/4	3/8	1/2		5/8	3/4		1		
Anchor O.D.	d_o	in. (mm)	0.25 (6.4)	0.375 (9.5)	0.5 (12.7)		0.625 (15.9)	0.75 (19.1)		1 (25.4)		
ANSI drill bit diameter	d_{bit}	in.	1/4	3/8	1/2		5/8	3/4		1		
Effective minimum embedment	h_{ef}	in. (mm)	1-1/2 (38)	2 (51)	2 (51)	3-1/4 (83)	3-1/8 (79)	4 (102)	3-3/4 (95)	5 (127)	4 (102)	5-3/4 (146)
Min hole depth	h_o	in. (mm)	2 (51)	2-5/8 (67)	2-5/8 (67)	4 (102)	3-7/8 (98)	4-3/4 (121)	4-1/2 (114)	5-3/4 (146)	5 (127)	6-3/4 (171)
Installation torque	T_{inst}	ft-lb (Nm)	4 (5)	20 (27)	40 (54)		60 (81)	110 (149)		150 (203)		
Expansion element clearance hole	d_h	in. (mm)	5/16 (7.9)	7/16 (11.1)	9/16 (14.3)		11/16 (17.5)	13/16 (20.6)		1-1/8 (28.6)		

3.3.6 KWIK Bolt 3 Expansion Anchor

Table 2 - Carbon Steel KB3 Strength Design

Design Information	Symbol	Units	Nominal anchor diameter													
			1/4	3/8		1/2		5/8		3/4						
Anchor O.D.	d_o	in. (mm)	0.25 (6.4)	0.375 (9.5)		0.5 (12.7)		0.625 (15.9)		0.75 (19.1)						
Effective min. embedment ²	h_{ef}	in. (mm)	1-1/2 (38)	2 (51)		2 (51)		3-1/4 (83)		3-1/8 (79)		4 (102)		3-3/4 (95)		5 (127)
Min. member thickness	h_{min}	in. (mm)	4 (102)	4 (102)	5 (127)	4 (102)	6 (152)	6 (152)	8 (203)	5 (127)	6 (152)	8 (203)	6 (152)	8 (203)	8 (203)	
Critical edge distance	c_{cr}	in. (mm)	2-3/4 (70)	4-1/2 (114)	3-7/8 (98)	4-7/8 (124)	3-5/8 (92)	6-3/4 (171)	5-5/8 (143)	7-1/2 (191)	9-1/2 (241)	7-1/2 (191)	9-3/4 (248)	7-1/2 (191)	9-1/2 (241)	
Min. edge distance	c_{min}	in. (mm)	1-3/8 (35)	2 (51)	1-1/2 (38)	2-1/8 (54)	2 (51)	1-5/8 (41)	1-5/8 (41)	2-1/4 (57)	1-3/4 (44)	1-3/4 (44)	2-3/4 (70)	2-5/8 (67)	2-1/2 (64)	
	for $s \geq$	in. (mm)	1-3/4 (44)	2-7/8 (73)	3-1/2 (89)	4-7/8 (124)	4-3/4 (121)	4-1/4 (108)	4 (102)	5-1/4 (133)	4-3/4 (121)	4 (102)	6-7/8 (175)	6-1/2 (165)	6-3/8 (162)	
Min. anchor spacing	s_{min}	in. (mm)	1-1/4 (32)	1-3/4 (44)	1-3/4 (44)	2-1/2 (64)	2-1/4 (57)	2 (51)	1-7/8 (48)	2-3/8 (60)	2-1/8 (54)	2-1/8 (54)	3-3/4 (95)	3-3/8 (86)	3-1/4 (83)	
	for $c \geq$	in. (mm)	1-5/8 (41)	2-3/8 (60)	2-3/8 (60)	2-5/8 (67)	2-3/8 (60)	2-1/4 (57)	2 (51)	3-1/8 (79)	2-3/8 (60)	2-1/4 (57)	3-3/4 (95)	3-3/8 (86)	3-3/8 (86)	
Min. hole depth in concrete	h_0	in. (mm)	2 (51)	2-5/8 (67)		2-5/8 (67)		4 (102)		3-7/8 (98)	4-3/4 (121)		4-1/2 (114)		5-3/4 (146)	
Min. specified yield strength	f_y	psi (N/mm ²)	84,800 (585)	84,800 (585)		84,800 (585)		84,800 (585)		84,800 (585)		84,800 (585)		84,800 (585)		
Min. specified ultimate strength	f_{ut}	psi (N/mm ²)	106,000 (731)	106,000 (731)		106,000 (731)		106,000 (731)		106,000 (731)		106,000 (731)		106,000 (731)		
Effective tensile stress area	A_{se}	in ² (mm ²)	0.02 (12.9)	0.06 (38.7)		0.11 (71.0)		0.11 (71.0)		0.17 (109.7)		0.17 (109.7)		0.24 (154.8)		
Steel strength in tension	N_s	lb (kN)	2,120 (9.4)	6,360 (28.3)		11,660 (51.9)		11,660 (51.9)		18,020 (80.2)		18,020 (80.2)		25,440 (113.2)		
Steel strength in shear	V_s	lb (kN)	1,640 (7.3)	4,470 (19.9)		6,635 (29.5)		6,750 (30.0)		12,230 (54.4)		12,230 (54.4)		15,660 (69.7)		16,594 (73.8)
Steel strength in shear, concrete on metal deck ³	$V_{sa,deck}$	lb (kN)		1,930 (8.6)		2,840 (12.6)		3,155 (14.0)		6,585 (29.3)		6,585 (29.3)		NP		
Pullout strength uncracked concrete ⁴	$N_{p,uncr}$	lb (kN)	1,575 (7.0)	NA		NA		6,800 (30.2)		NA		NA		10,585		
Pullout strength concrete on metal deck ⁵	$N_{p,deck,uncr}$	lb (kN)	1,750 (7.8)	2,245 (10.0)		2,730 (12.1)		2,730 (12.1)		4,765 (21.2)		4,765 (21.2)		NP		
Anchor category ⁶	1, 2 or 3	-	1													
Effectiveness factor k_{uncr} uncracked concrete ⁷	k_{uncr}	-	24													
Installation torque	T_{inst}	ft-lb (Nm)	4 (5)	20 (27)		40 (54)		40 (54)		60 (81)		60 (81)		110 (149)		
Axial stiffness in service load range	β	(lb/in)	116,150	162,850		203,500		191,100		222,150		170,700		207,400		164,000
COV β_{uncr}	β	%	60	42		29		29		25		21		19		24
Strength reduction factor Φ for tension, steel failure modes ⁸													0.75			
Strength reduction factor Φ for shear, steel failure modes ⁸													0.65			
Strength reduction factor Φ for tension, concrete failure modes, Condition B ⁹													0.65			
Strength reduction factor Φ for shear concrete, failure modes, Condition B ⁹													0.70			

For SI: 1 inch = 25.4 mm, 1lb = 4.45 N, 1 psi = 0.006895 MPa. For pound-in units: 1 mm = 0.03937 inches

1 For KB3 into the soffit of sand lightweight or normal-weight concrete on metal deck floor and roof assemblies, see Fig. 5.

2 See Figure 2.

3 NP (not permitted) denoted that the condition is not supported.

4 NA (not applicable) denotes that the condition does not govern for design.

5 NP (not permitted) denoted that the condition is not supported.

6 See ACI 318 Section D.4.4.

7 See ACI 318 Section D.5.2.2.

8 The carbon Steel KB3 is a ductile steel element as defined by ACI 318 Section D.1.

9 For use with the load combinations of ACI 318 Section 9.2 or IBC Section 1605.2.1. Condition B applies where supplementary reinforcement in conformance with ACI 318 Section D.4.4 is not provided, or where pull-out or pry out strength governs. For cases where the presence of supplementary reinforcement can be verified, the strength reduction factors associated with Condition A may be used.

KWIK Bolt 3 Expansion Anchor 3.3.6

Table 3 - Stainless Steel KB3 Strength Design Information

Design Information	Symbol	Units	Nominal anchor diameter														
			1/4	3/8		1/2			5/8		3/4		1				
Anchor O.D.	d_o	in. (mm)	0.25 (6.4)	0.375 (9.5)	0.5 (12.7)			0.625 (15.9)		0.75 (19.1)		1 (25.4)					
Effective min. embedment ¹	h_{ef}	in. (mm)	1.5 (38)	2 (51)	2 (51)	3.25 (83)	3.125 (79)	4 (102)	3.75 (95)	5 (127)	4 (102)	5.75 (146)					
Min. member thickness	h_{min}	in. (mm)	4 (102)	4 (102)	5 (127)	4 (102)	6 (152)	6 (152)	8 (203)	5 (127)	6 (152)	8 (203)	6 (152)	8 (203)	8 (203)	10 (254)	
Critical edge distance ²	c_{cr}	in. (mm)	3 (76)	4.375 (111)	3.875 (98)	4.875 (124)	4 (102)	6.75 (171)	5.75 (146)	7.375 (187)	9.5 (241)	7.5 (191)	10.5 (267)	9.25 (235)	9.75 (248)	10 (254)	11 (279)
Min. edge distance ²	c_{min}	in. (mm)	1.375 (35)	2 (51)	1.625 (41)	2.5 (64)	1.875 (48)	1.625 (41)	3.25 (83)	2.5 (64)	2.5 (64)	3.25 (83)	3 (76)	2.875 (73)	3.5 (89)	3 (76)	
	for $s \geq$	in. (mm)	1.75 (44)	4 (102)	3.625 (92)	5 (127)	4.625 (117)	4.5 (114)	4.25 (108)	5.625 (143)	5.25 (133)	5 (127)	7 (178)	6.875 (175)	6.625 (168)	6.75 (172)	6.75 (172)
Min. anchor spacing	s_{min}	in. (mm)	1.25 (32)	2 (51)	1.75 (44)	2.5 (64)	2.25 (57)	2.125 (54)	1.875 (48)	3.125 (79)	2.125 (54)	2.125 (54)	4 (102)	3.5 (89)	3.5 (89)	5 (127)	4.75 (121)
	for $c \geq$	in. (mm)	1.625 (41)	3.25 (83)	2.5 (64)	2.875 (73)	2.375 (60)	2.375 (60)	2.125 (54)	3.875 (98)	3 (76)	2.75 (70)	4.125 (105)	3.75 (95)	3.75 (95)	4.25 (108)	3.75 (95)
Min. hole depth in concrete	h_o	in. (mm)	2 (51)	2.625 (67)	2.625 (67)	4 (102)	3.875 (98)	4.75 (121)	4.5 (114)	5.75 (146)	5 (127)	6.75 (171)					
Min. specified yield strength	f_y	psi (N/mm ²)	92000 (634)	92,000 (634)	92,000 (634)	92,000 (634)	92,000 (634)	92,000 (634)	92,000 (634)	92,000 (634)	76,000 (524)	76,000 (524)					
Min. specified ult. strength	f_{ut}	psi (N/mm ²)	115000 (793)	115,000 (793)	115,000 (793)	115,000 (793)	115,000 (793)	115,000 (793)	115,000 (793)	115,000 (793)	90,000 (621)	90,000 (621)					
Effective tensile stress area	A_{se}	in ² (mm ²)	0.02 (12.9)	0.06 (38.7)	0.11 (71.0)	0.17 (109.7)	0.17 (109.7)	0.17 (109.7)	0.17 (109.7)	0.17 (109.7)	0.24 (154.8)	0.47 (303.2)					
Steel strength in tension	N_{sa}	lb (kN)	2300 (10.2)	6,900 (30.7)	12,650 (56.3)	12,650 (56.3)	19,550 (87.0)	19,550 (87.0)	19,550 (87.0)	21,600 (96.1)	21,600 (96.1)	42,311 (188.2)					
Steel strength in shear	V_{sa}	lb (kN)	1680 (7.5)	4,980 (22.2)	4,195 (18.7)	6,940 (30.9)	8,955 (39.8)	14,300 (63.6)	11,900 (52.9)	23,545 (104.7)	12,510 (55.6)	30,000 (133.5)					
Steel strength in shear, concrete on metal deck	$V_{sa,deck}$	lb (kN)	2,020 (9.0)	2,580 (11.5)	1,745 (7.8)	1,745 (7.8)	5,690 (25.3)	5,690 (25.3)	NP	NP	NP	NP					
Pullout strength uncracked concrete	$N_{p,uncr}$	lb (kN)	1325 (5.9)	3,120 (13.9)	3,310 (14.7)	6,340 (28.2)	6,230 (27.7)	7,830 (34.8)	8,555 (38.1)	10,830 (48.2)	NA	15,550 (69.2)					
Pullout strength concrete on metal deck ⁵	$N_{p,deck,uncr}$	lb (kN)	1805 (8.0)	2,580 (11.5)	1,945 (8.7)	1,945 (8.7)	4,430 (19.7)	4,430 (19.7)	NP	NP	NP	NP					
Anchor category ⁶	1, 2 or 3	-	2	1													
Effectiveness factor uncracked concrete ⁷	k_{uncr}	-	24														
Installation torque	T_{inst}	ft-lb (Nm)	4 (5)	20 (27)	40 (54)	40 (54)	60 (81)	60 (81)	110 (149)	110 (149)	150 (203)	150 (203)					
Axial stiffness in service load range	β	(lb/in)	57,400	158,300	154,150	77,625	227,600	189,200	275,600	187,000	126,400	174,800					
COV	β	%	40	34	36	17	31	22	35	21	38	22					
Strength reduction factor Φ for tension, steel failure modes												0.75					
Strength reduction factor Φ for shear, steel failure modes ⁸												0.65					
Strength reduction factor Φ for tension concrete failure modes, Condition B ⁹												0.65					
Strength reduction factor Φ for shear concrete failure modes, Condition B ⁹												0.70					

1 See Figure 1.

2 For KB3 into the soffit of sand lightweight or normal-weight concrete on metal deck floor and roof assemblies, see Figure 3.

3 NP (not permitted) denoted that the condition is not supported.

4 NA (not applicable) denotes that the condition does not govern for design.

5 NP (not permitted) denoted that the condition is not supported.

6 See ACI 318 Section D.4.4.

7 See ACI 318 Section D.5.2.2.

8 The KB3 is a ductile steel element as defined by ACI 318 Section D.1.

9 For use with the load combinations of ACI 318 Section 9.2. Condition B applies where supplementary reinforcement in conformance with ACI 318 Section D.4.4 is not provided, or where pull-out or pry out strength governs. For cases where the presence of supplementary reinforcement can be verified, the strength reduction factors associated with Condition A may be used.

3.3.6 KWIK Bolt 3 Expansion Anchor

Table 4 - Hot-Dip Galvanized KB3 Strength Design Information

Design Information	Symbol	Units	Nominal anchor Diameter									
			1/2		5/8			3/4				
Anchor O.D.	d_o	in. (mm)	0.5 (12.)		0.625 (15.9)			0.75 (19.1)				
Effective min. embedment ²	h_{ef}	in. (mm)	2 (51)		3.25 (83)		3.125 (79)	4 (102)		3.75 (95)		5 (127)
Min. member thickness	h_{min}	in. (mm)	4 (102)	6 (152)	6 (152)	8 (203)	5 (127)	6 (152)	8 (203)	6 (152)	8 (203)	8 (203)
Critical edge distance	c_{cr}	in. (mm)	4.875 (124)	3.625 (92)	6.75 (171)	5.625 (143)	7.5 (191)	9.5 (241)	7.5 (191)	9.75 (248)	7.5 (191)	9.5 (241)
Min. edge distance	c_{min}	in. (mm)	3.25 (83)	2.625 (67)	2 (51)		2.25 (57)	2 (51)	1.875 (48)	3.5 (89)		3.625 (92)
	for $s \geq$	in. (mm)	6.25 (159)	5.5 (140)	4.875 (124)		5.25 (133)	5 (127)	4.75 (121)	7.5 (191)		7.375 (187)
Min. anchor spacing	s_{min}	in. (mm)	3.125 (79)	2.75 (70)	2.375 (60)	2.125 (54)	2.5 (64)	2.125 (54)	2.125 (54)	4 (102)		3.875 (98)
	for $c \geq$	in. (mm)	3.75 (95)	2.75 (70)	2.625 (67)	2.25 (57)	3.5 (89)	2.5 (64)	2.25 (57)	6.5 (165)		4.75 (121)
Min. hole depth in concrete	h_o	in. (mm)	2.625 (67)		4 (102)		3.875 (98)	4.75 (121)		4.5 (114)		5.75 (146)
Min. specified yield strength	f_y	psi (N/mm ²)	84,800 (585)			84,800 (585)			84,800 (585)			
Min. specified ult. strength	f_{ut}	psi (N/mm ²)	106,000 (731)			106,000 (731)			106,000 (731)			
Effective tensile stress area	A_{se}	in ² (mm ²)	0.11 (71.0)			0.17 (109.7)			0.24 (154.8)			
Steel strength in tension	N_{sa}	lb (kN)	11,660 (51.9)			18,020 (80.2)			25,440 (113.2)			
Steel strength in shear	V_{sa}	lb (kN)	4,200 (18.7)		5,870 (26.1)		11,635 (51.8)		17,000 (75.6)			
Pullout strength uncracked concrete ⁴	$N_{p,uncr}$	lb (kN)	NA		6,540 (29.1)		6,465 (28.8)		9,375 (41.7)		NA (45.3)	
Anchor category ⁷	1, 2 or 3	-	1									
Effectiveness factor uncracked concrete ⁷	k_{uncr}	-	24									
Installation torque	T_{inst}	ft-lb (Nm)	40 (54)			60 (81)			110 (149)			
Axial stiffness in service load range	β	(lb/in)	177,000		332,850		347,750	190,130		364,725		314,650
COV	β	%	42		18		37	36		27		21
Strength reduction factor f for tension, steel failure modes ⁵											0.75	
Strength reduction factor f for shear, steel failure modes ⁵											0.65	
Strength reduction factor f for tension concrete failure modes, Condition B ⁶											0.65	
Strength reduction factor f for shear concrete failure modes, Condition B ⁶											0.70	

1 See Table 16 and the associated figure.

2 NA (not applicable) denotes that this value does not govern for design.

3 See ACI 318 Section D.4.4.

4 See ACI 318 Section D.5.2.2.

5 The KB3 is a ductile steel element as defined by ACI 318 Section D.1

6 For use with the load combinations of ACI 318 Section 9.2. Condition B applies where supplementary reinforcement in conformance with ACI 318 Section D.4.4 is not provided, or where pull-out or pry out strength governs. For cases where the presence of supplementary reinforcement can be verified, the strength reduction factors associated with Condition A may be used.

KWIK Bolt 3 Expansion Anchor 3.3.6

Figure 2 - Interpolation of Minimum Edge Distance and Anchor Spacing

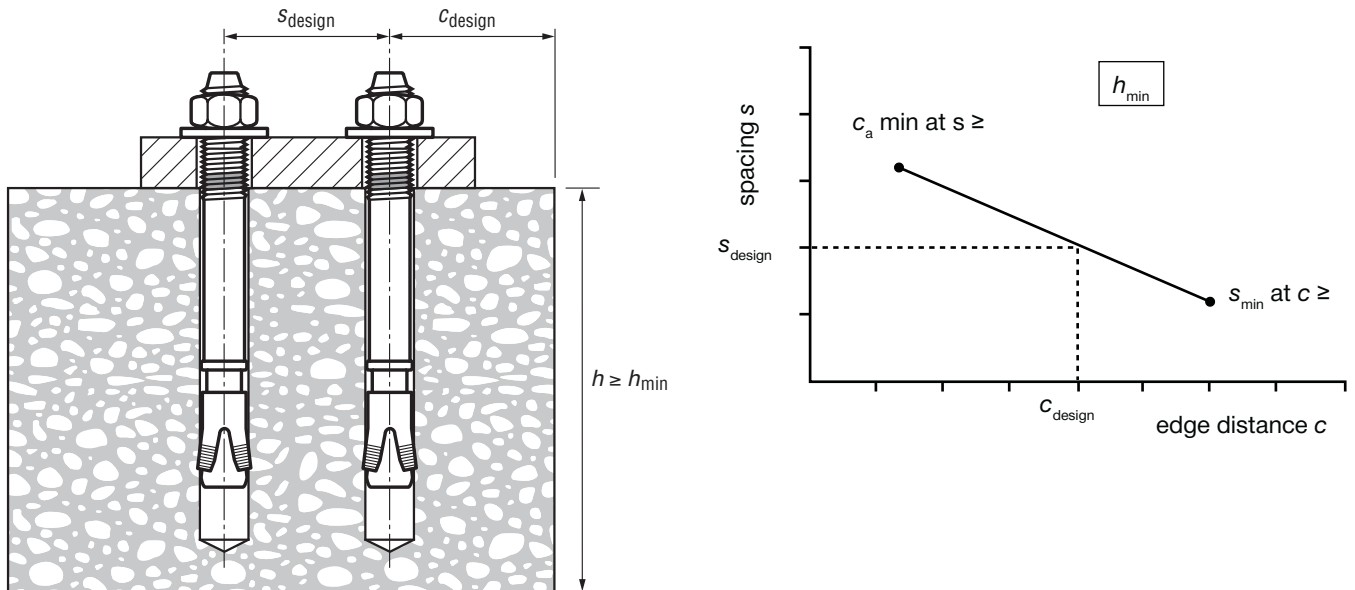

Length Identification System

Length ID marking on bolt head	A	B	C	D	E	F	G	H	I	J	K	L	M	N	O	P	Q	R	S	T
From	1-1/2	2	2-1/2	3	3-1/2	4	4-1/2	5	5-1/2	6	6-1/2	7	7-1/2	8	8-1/2	9	9-1/2	10	11	12
Up to of anchor, (in.) but not including	2	2-1/2	3	3-1/2	4	4-1/2	5	5-1/2	6	6-1/2	7	7-1/2	8	8-1/2	9	9-1/2	10	11	12	13

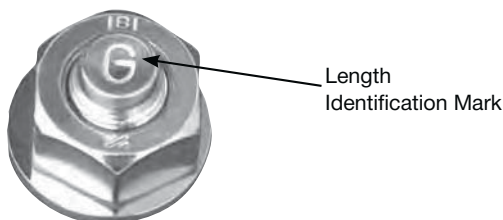

3.3.6 KWIK Bolt 3 Expansion Anchor

3.3.6.4 Allowable Stress Design

Table 5 - KWIK Bolt 3 Specifications and Properties¹

Details		Bolt Size	in.			1/4			3/8			1/2		
			(mm)			(6.4)			(9.5)			(12.7)		
d_{bit}	nominal bit diameter ²	in.	1/4			3/8			1/2					
$h_{min}/h_{nom}/h_{deep}$	depth of embedment	in.	1-1/8	2	3	1-5/8	2-1/2	3-1/2	2-1/4	3-1/2	4-3/4			
		(mm)	(29)	(51)	(76)	(41)	(64)	(89)	(57)	(89)	(121)			
h_o	minimum/standard/deep hole depth	in.	1-3/8	2-1/4	3-1/4	2	2-7/8	3-7/8	2-3/4	4	5-1/4			
		(mm)	(35)	(57)	(83)	(51)	(73)	(89)	(70)	(102)	(133)			
d_h	fixture hole	in.	5/16			7/16			9/16					
		(mm)	(8)			(11)			(14)					
T_{inst} Installation Torque	Normal weight & Light weight Concrete	Carbon Steel	ft-lb			20			40					
		HDG	(Nm)			(27)			(54)					
		Stainless Steel	ft-lb			20			40					
		(Nm)	(5)			(27)			(54)					
	Grout Filled Block	Carbon Steel	ft-lb			15			25					
			(Nm)			(20)			(34)					
h	min. base material thickness	in.	3 inch (76 mm) or 1.3 times embedment, whichever number is greater											
Bolt Fracture Load	Carbon Steel		2900 lb ^{4,6}			7200 lb ^{4,6}			12400 lb ⁴					
	HDG		no offering			no offering			12400 lb ⁴					
	Stainless Steel		2900 lb ^{4,7}			7200 lb ^{4,7}			12400 lb ⁴					

Details		Bolt Size	in.			3/4			1		
			(mm)			(19.1)			(25.4)		
d_{bit}	nominal bit diameter ²	in.	5/8			3/4			1		
$h_{min}/h_{nom}/h_{deep}$	depth of embedment	in.	2-3/4	4	5-1/2	3-1/4	4-3/4	6-1/2 ³	4-1/2	6	9
		(mm)	(70)	(102)	(140)	(83)	(121)	(165)	(114)	(152)	(229)
h_o	minimum/standard/deep hole depth	in.	3-3/8	4-5/8	6-1/8	4	5-1/2	7	5-1/2	7	10
		(mm)	(86)	(117)	(156)	(102)	(140)	(178)	(140)	(178)	(254)
d_h	fixture hole	in.	11/16			13/16			1-1/8		
		(mm)	(17)			(21)			(29)		
T_{inst} Installation Torque	Normal weight & Light weight Concrete	Carbon Steel	ft-lb			110			150		
		HDG	(Nm)			(149)			(203)		
		Stainless Steel	ft-lb			110			150		
		(Nm)	(81)			(149)			(203)		
	Grout Filled Block	Carbon Steel	ft-lb			120			-		
			(Nm)			(163)					
h	min. base material thickness	in.	3 inch (76 mm) or 1.3 times embedment, whichever number is greater								
Bolt Fracture Load	Carbon Steel		19600 lb ⁴			28700 lb ^{4,8}			$f_{ut} \geq 88 \text{ ksi}, f_y \geq 75 \text{ ksi}^5$		
	HDG		19600 lb ⁴			28700 lb ⁴			no offering		
	Stainless Steel		21900 lb ⁴			$f_{ut} \geq 76 \text{ ksi}, f_y \geq 64 \text{ ksi}^5$			$f_{ut} \geq 76 \text{ ksi}, f_y \geq 64 \text{ ksi}^5$		

- 1 See KWIK Bolt 3 Product Line Table in Section 3.3.6.6 for a full list and anchor length and thread length configurations.
- 2 Loads for KWIK Bolt 3 are applicable for both carbide drill bits and matched tolerance Hilti DD-B or DD-C diamond core bits in sizes ranging from 1/2 inch to 1 inch.
- 3 The deep embedment depth for stainless steel KWIK Bolt 3 anchors is 8 inch (203 mm).
- 4 Bolt fracture loads are determined by testing in a jig as part of product quality control. These values are not intended for design purposes.
- 5 Bolt strength specified by minimum tensile and yield strength. Bolt fracture load not applicable.
- 6 Bolt fracture load not applicable to carbon steel Countersunk KWIK Bolt 3. The tensile and yield strengths are $f_{ut} \geq 105 \text{ ksi}$ and $f_y \geq 90 \text{ ksi}$.
- 7 Bolt fracture load not applicable to stainless steel Countersunk KWIK Bolt 3. The tensile and yield strengths are $f_{ut} \geq 90 \text{ ksi}$ and $f_y \geq 76 \text{ ksi}$.
- 8 For 3/4 x 12, $f_{ut} \geq 88 \text{ ksi}$ and $f_y \geq 75 \text{ ksi}$. Bolt fracture load not applicable.

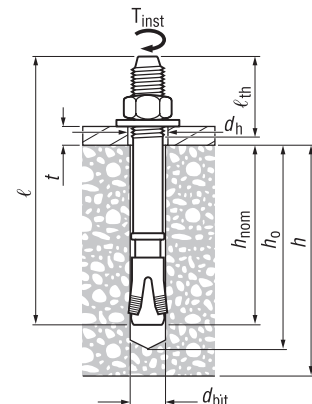

KWIK Bolt 3 Expansion Anchor 3.3.6

Table 6 - Carbon Steel KWIK Bolt 3 Allowable Loads in Normal-Weight Concrete¹

Anchor Diameter in. (mm)	Embedment Depth in. (mm)	$f'_c = 2000$ psi (13.8 MPa)		$f'_c = 3000$ psi (20.7 MPa)		$f'_c = 4000$ psi (27.6 MPa)		$f'_c = 6000$ psi (41.4 MPa)	
		Tension lb (kN)	Shear lb (kN)	Tension lb (kN)	Shear lb (kN)	Tension lb (kN)	Shear lb (kN)	Tension lb (kN)	Shear lb (kN)
1/4 (6.4)	1-1/8 (29)	300 (1.3)	530 (2.4)	365 (1.6)	530 (2.4)	430 (1.9)	530 (2.4)	550 (2.4)	530 (2.4)
	2 (51)	635 (2.8)		715 (3.2)		800 (3.6)		845 (3.8)	
	3 (76)	755 (3.4)		795 (3.5)		840 (3.7)			
3/8 (9.5)	1-5/8 (41)	730 (3.2)	1135 (5.0)	910 (4.0)	1275 (5.7)	1095 (4.9)	1315 (5.8)	1090 (4.8)	1315 (5.8)
	2-1/2 (64)	1260 (5.6)	1315 (5.8)	1555 (6.9)	1315 (5.8)	1850 (8.2)		2060 (9.2)	
	3-1/2 (89)	1580 (7.0)		1770 (7.9)		1965 (8.7)		2150 (9.6)	
1/2 (12.7)	2-1/4 (57)	1235 (5.5)	1865 (8.3)	1430 (6.4)	2300 (10.2)	1620 (7.2)	2405 (10.7)	1975 (8.8)	2415 (10.7)
	3-1/2 (89)	1930 (8.6)	2415 (10.7)	2185 (9.7)	2415 (10.7)	2440 (10.9)	2415 (10.7)	3240 (14.4)	
	4-3/4 (121)	2135 (9.5)		2355 (10.5)		2575 (11.5)		3620 (16.1)	
5/8 (15.9)	2-3/4 (70)	1920 (8.5)	2750 (12.2)	2065 (9.2)	3410 (15.2)	2210 (9.8)	3785 (16.8)	2830 (12.6)	3910 (17.4)
	4 (102)	2660 (11.8)	3910 (17.4)	3020 (13.4)	3910 (17.4)	3385 (15.1)	3910 (17.4)	4770 (21.2)	
	5-1/2 (140)	3285 (14.6)		3695 (16.4)		4100 (18.2)		5325 (23.7)	
3/4 (19.1)	3-1/4 (83)	2120 (9.4)	4090 (18.2)	2425 (10.8)	4900 (21.8)	2730 (12.1)	5310 (23.6)	3785 (16.8)	5310 (23.6)
	4-3/4 (121)	3240 (14.4)	5340 (23.8)	4260 (18.9)	5340 (23.8)	5285 (23.5)	5495 (24.4)	6155 (27.4)	6225 (27.7)
	6-1/2 (165)	4535 (20.2)		5860 (26.1)		7185 (32)		7005 (31.2)	
1 (25.4)	4-1/2 (114)	3330 (14.8)	7070 (31.4)	4050 (18.0)	7600 (33.8)	4670 (20.8)	8140 (36.2)	5070 (22.6)	9200 (40.9)
	6 (152)	4930 (21.9)	9200 (40.9)	6000 (26.7)	9200 (40.9)	7070 (31.4)	9200 (40.9)	8400 (37.4)	
	9 (229)	6670 (29.7)		7670 (34.1)		8670 (38.6)		10670 (47.5)	

¹ Intermediate load values for other concrete strengths and embedments can be calculated by linear interpolation.

3.3.6 KWIK Bolt 3 Expansion Anchor

Table 7 - Carbon Steel KWIK Bolt 3 Ultimate Loads in Normal-Weight Concrete¹

Anchor Diameter in. (mm)	Embedment Depth in. (mm)	$f'_c = 2000$ psi (13.8 MPa)		$f'_c = 3000$ psi (20.7 MPa)		$f'_c = 4000$ psi (27.6 MPa)		$f'_c = 6000$ psi (41.4 MPa)	
		Tension lb (kN)	Shear lb (kN)	Tension lb (kN)	Shear lb (kN)	Tension lb (kN)	Shear lb (kN)	Tension lb (kN)	Shear lb (kN)
1/4 (6.4)	1-1/8 (29)	1120 (5.0)	1995 (8.9)	1370 (6.1)	1995 (8.9)	1615 (7.2)	1995 (8.9)	2060 (9.2)	1995 (8.9)
	2 (51)	2375 (10.5)		2690 (12.0)		3000 (13.3)		3165 (14.1)	
	3 (76)	2830 (12.6)		2990 (13.3)		3150 (14.0)			
3/8 (9.5)	1-5/8 (41)	2740 (12.2)	4250 (18.9)	3420 (15.2)	4790 (21.3)	4100 (18.2)	4930 (21.9)	4095 (18.2)	4930 (21.9)
	2-1/2 (64)	4720 (21.0)	4930 (21.9)	5830 (25.9)	4930 (21.9)	6935 (30.8)		7730 (34.4)	
	3-1/2 (89)	5925 (26.4)		6645 (29.6)		7365 (32.8)		8055 (35.8)	
1/2 (12.7)	2-1/4 (57)	4635 (20.6)	7000 (31.1)	5355 (23.8)	8630 (38.4)	6075 (27.0)	9030 (40.2)	7410 (33.0)	9065 (40.3)
	3-1/2 (89)	7240 (32.2)	9065 (40.3)	8195 (36.5)	9065 (40.3)	9145 (40.7)	9065 (40.3)	12140 (54.0)	
	4-3/4 (121)	8000 (35.6)		8830 (39.3)		9655 (42.9)		13585 (60.4)	
5/8 (15.9)	2-3/4 (70)	7210 (32.1)	10315 (45.9)	7750 (34.5)	12790 (56.9)	8285 (36.9)	14195 (63.1)	10615 (47.2)	14650 (65.2)
	4 (102)	9975 (44.4)	14650 (65.2)	11335 (50.4)	14650 (65.2)	12690 (56.4)	14650 (65.2)	17890 (79.6)	
	5-1/2 (140)	12315 (54.8)		13850 (61.6)		15385 (68.4)		19970 (88.8)	
3/4 (19.1)	3-1/4 (83)	7955 (35.4)	15335 (68.2)	9100 (40.5)	18375 (81.7)	10245 (45.6)	19910 (88.6)	14185 (63.1)	19910 (88.6)
	4-3/4 (121)	12150 (54.0)	20030 (89.1)	15985 (71.1)	20030 (89.1)	19820 (86.2)	20605 (91.7)	23085 (102.7)	23355 (103.9)
	6-1/2 (165)	17000 (75.6)		21970 (97.7)		26935 (119.8)		26260 (116.8)	
1 (25.4)	4-1/2 (114)	12500 (55.6)	26500 (117.9)	15200 (67.6)	28500 (126.8)	17500 (77.8)	30500 (135.7)	19000 (84.5)	34500 (153.5)
	6 (152)	18500 (82.3)	34500 (153.5)	22500 (100.1)	34500 (153.5)	26500 (117.9)	34500 (153.5)	31500 (140.1)	
	9 (229)	25000 (111.2)		28750 (127.9)		32500 (144.6)		40000 (177.9)	

¹ Intermediate load values for other concrete strengths and embedments can be calculated by linear interpolation.

KWIK Bolt 3 Expansion Anchor 3.3.6

Table 8 - Stainless Steel KWIK Bolt 3 Allowable Loads in Normal-Weight Concrete¹

Anchor Diameter in. (mm)	Embedment Depth in. (mm)	$f'_c = 2000$ psi (13.8 MPa)		$f'_c = 3000$ psi (20.7 MPa)		$f'_c = 4000$ psi (27.6 MPa)		$f'_c = 6000$ psi (41.4 MPa)	
		Tension lb (kN)	Shear lb (kN)	Tension lb (kN)	Shear lb (kN)	Tension lb (kN)	Shear lb (kN)	Tension lb (kN)	Shear lb (kN)
1/4 (6.4)	1-1/8 (29)	260 (1.2)	595 (2.6)	320 (1.4)	675 (3.0)	380 (1.7)	725 (3.2)	470 (2.1)	805 (3.6)
	2 (51)	540 (2.4)		625 (2.8)		705 (3.1)		805 (3.6)	
	3 (76)	685 (3)	750 (3.3)	810 (3.6)					
3/8 (9.5)	1-5/8 (41)	605 (2.7)	880 (3.9)	670 (3.0)	1110 (4.9)	730 (3.2)	1345 (6.0)	950 (4.2)	1690 (7.5)
	2-1/2 (64)	1285 (5.7)	1570 (7.0)	1430 (6.4)	1570 (7.0)	1575 (7.0)	1590 (7.1)	1940 (8.6)	1590 (7.1)
	3-1/2 (89)	1620 (7.2)		1755 (7.8)		1885 (8.4)		2035 (9.1)	
1/2 (12.7)	2-1/4 (57)	1015 (4.5)	1875 (8.3)	1230 (5.5)		2130 (9.5)	1450 (6.4)	2380 (10.6)	
	3-1/2 (89)	1445 (6.4)	3010 (13.4)	1975 (8.8)	3010 (13.4)	2510 (11.2)	3045 (13.5)	2655 (11.8)	3045 (13.5)
	4-3/4 (121)	1990 (8.9)		2250 (10.0)		2985 (13.3)			
5/8 (15.9)	2-3/4 (70)	1650 (7.3)	2875 (12.8)	1755 (7.8)		3485 (15.5)	1860 (8.3)	4095 (18.2)	
	4 (102)	2455 (10.9)	4625 (20.6)	2900 (12.9)	4625 (20.6)	3340 (14.9)	4625 (20.6)	4395 (19.5)	
	5-1/2 (140)	3480 (15.5)		3885 (17.3)		4290 (19.1)		6260 (27.8)	
3/4 (19.1)	3-1/4 (83)	1550 (6.9)	3945 (17.5)	1950 (8.7)		4260 (18.9)	2350 (10.5)	5645 (25.1)	2610 (11.6)
	4-3/4 (121)	2510 (11.2)	5535 (24.6)	3250 (14.5)	5535 (24.6)	3870 (17.2)	4670 (20.8)		
	8 (203)	2930 (13.0)		3735 (16.6)		4530 (20.2)			5120 (22.8)
1 (25.4)	4-1/2 (114)	3120 (13.9)	6080 (27.0)	3870 (17.2)		6770 (30.1)	4610 (20.5)	7470 (33.2)	4800 (21.4)
	6 (152)	4400 (19.6)	7470 (33.2)	6400 (28.5)	7470 (33.2)	7200 (32.0)	7330 (32.6)		
	9 (229)	5600 (24.9)		8000 (35.6)		9390 (41.8)			9390 (41.8)

¹ Intermediate load values for other concrete strengths and embedments can be calculated by linear interpolation.

3.3.6 KWIK Bolt 3 Expansion Anchor

Table 9 - Stainless Steel KWIK Bolt 3 Ultimate Loads in Normal-Weight Concrete¹

Anchor Diameter in. (mm)	Embedment Depth in. (mm)	$f'_c = 2000$ psi (13.8 MPa)		$f'_c = 3000$ psi (20.7 MPa)		$f'_c = 4000$ psi (27.6 MPa)		$f'_c = 6000$ psi (41.4 MPa)	
		Tension lb (kN)	Shear lb (kN)	Tension lb (kN)	Shear lb (kN)	Tension lb (kN)	Shear lb (kN)	Tension lb (kN)	Shear lb (kN)
1/4 (6.4)	1-1/8 (29)	980 (4.4)	2240 (10.0)	1205 (5.4)	2530 (11.3)	1430 (6.4)	2725 (12.1)	1755 (7.8)	3020 (13.4)
	2 (51)	2035 (9.1)		2340 (10.4)		2640 (11.7)		3020 (13.4)	
	3 (76)	2580 (11.5)	2810 (12.5)	3040 (13.5)					
3/8 (9.5)	1-5/8 (41)	2275 (10.1)	3300 (14.7)	2505 (11.1)	4175 (18.6)	2735 (12.2)	5045 (22.4)	3560 (15.8)	6015 (26.8)
	2-1/2 (64)	4825 (21.5)	5900 (26.2)	5365 (23.9)	5900 (26.2)	5905 (26.3)	5954 (26.5)	7270 (32.3)	5954 (26.5)
	3-1/2 (89)	6075 (27.0)		6575 (29.2)		7075 (31.5)		7625 (33.9)	
1/2 (12.7)	2-1/4 (57)	3805 (16.9)	7030 (31.3)	4620 (20.6)		7980 (35.5)	5435 (24.2)	8930 (39.7)	
	3-1/2 (89)	5415 (24.1)	11290 (50.2)	7410 (33.0)	11290 (50.2)	9405 (41.8)	11410 (50.8)	9950 (44.3)	11410 (50.8)
	4-3/4 (121)	7460 (33.2)		8435 (37.5)				11200 (49.8)	
5/8 (15.9)	2-3/4 (70)	6185 (27.5)	10790 (48.0)	6580 (29.3)		13075 (58.2)		6975 (31.0)	
	4 (102)	9205 (40.9)	17355 (77.2)	10870 (48.4)	17355 (77.2)	12530 (55.7)	17355 (77.2)	16490 (73.4)	
	5-1/2 (140)	13040 (58.0)		14560 (64.8)		16080 (71.5)		23475 (104.4)	
3/4 (19.1)	3-1/4 (83)	5800 (25.8)	14790 (65.8)	7300 (32.5)		15980 (71.1)	8800 (39.1)	21160 (94.1)	9800 (43.6)
	4-3/4 (121)	9400 (41.8)	20750 (92.3)	11950 (53.2)	20750 (92.3)	14500 (64.5)	17500 (77.8)		
	8 (203)	11000 (48.9)		14000 (62.3)		17000 (75.6)			19200 (85.4)
1 (25.4)	4-1/2 (114)	11700 (52.0)	22800 (101.4)	14500 (64.5)		25400 (113.0)	17300 (77.0)	28000 (124.6)	18000 (80.1)
	6 (152)	16500 (73.4)	28000 (124.6)	21750 (96.7)	28000 (124.6)	27000 (120.1)	27500 (122.3)		
	9 (229)	21000 (93.4)		28100 (125.0)		35200 (156.6)			35200 (156.6)

¹ Intermediate load values for other concrete strengths and embedments can be calculated by linear interpolation.

KWIK Bolt 3 Expansion Anchor 3.3.6

Table 10 - Hot-Dip Galvanized KWIK Bolt 3 Allowable Loads in Normal-Weight Concrete¹

Anchor Diameter in. (mm)	Embedment Depth in. (mm)	$f'_c = 2000$ psi (13.8 MPa)		$f'_c = 3000$ psi (20.7 MPa)		$f'_c = 4000$ psi (27.6 MPa)		$f'_c = 6000$ psi (41.4 MPa)	
		Tension lb (kN)	Shear lb (kN)	Tension lb (kN)	Shear lb (kN)	Tension lb (kN)	Shear lb (kN)	Tension lb (kN)	Shear lb (kN)
1/2 (12.7)	2-1/4 (57)	1125 (5.0)	1785 (7.9)	1265 (5.6)	1785 (7.9)	1400 (6.2)	2190 (9.7)	1655 (7.4)	2190 (9.7)
	3-1/2 (89)	1895 (8.4)	2190 (9.7)	2115 (9.4)	2190 (9.7)	2335 (10.4)		3105 (13.8)	
	4-3/4 (121)	2215 (9.9)		2530 (11.3)		2845 (12.7)		3740 (16.6)	
5/8 (15.9)	2-3/4 (70)	1785 (7.9)	3780 (16.8)	1965 (8.7)	3780 (16.8)	2140 (9.5)	3780 (16.8)	2745 (12.2)	3790 (16.8)
	4 (102)	2545 (11.3)		3155 (14.0)		3765 (16.7)		5280 (23.5)	
	5-1/2 (140)	3375 (15.0)		4030 (17.9)		4030 (17.9)		6055 (26.9)	
3/4 (19.1)	3-1/4 (83)	2355 (10.5)	4240 (18.9)	2545 (11.3)	4240 (18.9)	2735 (12.2)	5340 (23.8)	2825 (12.6)	5340 (23.8)
	4-3/4 (121)	3730 (16.6)	5340 (23.8)	4350 (19.3)	5340 (23.8)	4970 (22.1)		5805 (25.8)	
	8 (203)	5115 (22.8)		5805 (25.8)		6495 (28.9)		7520 (33.5)	

¹ Intermediate load values for other concrete strengths and embedments can be calculated by linear interpolation.

Table 11 - Hot-Dip Galvanized KWIK Bolt 3 Ultimate Loads in Normal-Weight Concrete¹

Anchor Diameter in. (mm)	Embedment Depth in. (mm)	$f'_c = 2000$ psi (13.8 MPa)		$f'_c = 3000$ psi (20.7 MPa)		$f'_c = 4000$ psi (27.6 MPa)		$f'_c = 6000$ psi (41.4 MPa)	
		Tension lb (kN)	Shear lb (kN)	Tension lb (kN)	Shear lb (kN)	Tension lb (kN)	Shear lb (kN)	Tension lb (kN)	Shear lb (kN)
1/2 (12.7)	2-1/4 (57)	4220 (18.8)	6695 (29.8)	4740 (21.1)	6695 (29.8)	5255 (23.4)	8210 (36.5)	6210 (27.6)	8210 (36.5)
	3-1/2 (89)	7100 (31.6)	8210 (36.5)	7935 (35.3)	8210 (36.5)	8765 (39.0)		11645 (51.8)	
	4-3/4 (121)	8310 (37.0)		9495 (42.2)		10675 (47.5)		14030 (62.4)	
5/8 (15.9)	2-3/4 (70)	6690 (29.8)	14170 (63.0)	7360 (32.7)	14170 (63.0)	8030 (35.7)	14170 (63.0)	10295 (45.8)	14170 (63.0)
	4 (102)	9550 (42.5)		11835 (52.6)		14120 (62.8)		19800 (88.1)	
	5-1/2 (140)	12650 (56.3)		15115 (67.2)		17575 (78.2)		22705 (101.0)	
3/4 (19.1)	3-1/4 (83)	8825 (39.3)	15900 (70.7)	9545 (42.5)	15900 (70.7)	10260 (45.6)	20030 (89.1)	10600 (47.2)	20030 (89.1)
	4-3/4 (121)	13995 (62.3)	20030 (89.1)	16315 (72.6)	20030 (89.1)	18635 (82.9)		21765 (96.8)	
	6-1/2 (165)	19180 (85.3)		21770 (96.8)		24355 (108.3)		28210 (125.5)	

¹ Intermediate load values for other concrete strengths and embedments can be calculated by linear interpolation.

3.3.6 KWIK Bolt 3 Expansion Anchor

Table 12 - Carbon Steel KWIK Bolt 3 Allowable Loads in Lightweight Concrete^{1,2}

Anchor Diameter in. (mm)	Anchor Depth in. (mm)		Tension		Tension		Tension		Shear	
			$f'_c = 2000$ psi (13.8 MPa) lb (kN)	$f'_c = 3000$ psi (20.7 MPa) lb (kN)	$f'_c = 4000$ psi (27.6 MPa) lb (kN)	$f'_c = 2000$ psi (13.8 MPa) lb (kN)				
1/4 (6.4)	1-1/8	(29)	275	(1.2)	335	(1.5)	400	(1.8)	400	(1.8)
	2	(51)	595	(2.6)	675	(3.0)	750	(3.3)	400	(1.8)
3/8 (9.5)	1-5/8	(41)	585	(2.6)	685	(3.0)	785	(3.5)	890	(4.0)
	2-1/2	(64)	1120	(5.0)	1340	(6.0)	1560	(6.9)	1345	(5.9)
1/2 (12.7)	2-1/4	(57)	1160	(5.2)	1340	(6.0)	1520	(6.8)	1750	(7.8)
	3-1/2	(89)	1810	(8.1)	2050	(9.1)	2285	(10.2)	2835	(12.6)
5/8 (15.9)	2-3/4	(70)	1560	(6.9)	1815	(8.1)	2070	(9.2)	2580	(11.5)
	4	(102)	2485	(11.1)	2830	(12.6)	3170	(14.1)	3360	(14.9)
3/4 (19.1)	3-1/4	(83)	1920	(8.5)	2240	(10.0)	2560	(11.4)	3835	(17.1)
	4-3/4	(121)	3035	(13.5)	3995	(17.8)	4955	(22)	5010	(22.3)

1 Allowable loads based on safety factor of 4.0.

2 Intermediate load values for other concrete strengths and embedments can be calculated by linear interpolation.

Table 13 - Stainless Steel KWIK Bolt 3 Allowable Loads in Lightweight Concrete^{1,2}

Anchor Diameter in. (mm)	Anchor Depth in. (mm)		Tension		Tension		Tension		Shear	
			$f'_c = 2000$ psi (13.8 MPa) lb (kN)	$f'_c = 3000$ psi (20.7 MPa) lb (kN)	$f'_c = 4000$ psi (27.6 MPa) lb (kN)	$f'_c = 2000$ psi (13.8 MPa) lb (kN)				
1/4 (6.4)	1-1/8	(29)	245	(1.1)	300	(1.3)	355	(1.6)	545	(2.4)
	2	(51)	510	(2.3)	585	(2.6)	660	(2.9)	630	(2.8)
3/8 (9.5)	1-5/8	(41)	560	(2.5)	625	(2.8)	685	(3.0)	825	(3.7)
	2-1/2	(64)	920	(4.1)	1200	(5.3)	1475	(6.6)	1345	(6.0)
1/2 (12.7)	2-1/4	(57)	950	(4.2)	1155	(5.1)	1360	(6.0)	1755	(7.8)
	3-1/2	(89)	1355	(6.0)	1855	(8.3)	2350	(10.5)	2955	(13.1)
5/8 (15.9)	2-3/4	(70)	1470	(6.5)	1605	(7.1)	1745	(7.8)	2695	(12.0)
	4	(102)	2300	(10.2)	2715	(12.1)	3130	(13.9)	4500	(20.0)

1 Allowable loads based on safety factor of 4.0.

2 Intermediate load values for other concrete strengths and embedments can be calculated by linear interpolation.

Table 14 - Carbon Steel KWIK Bolt 3 Allowable Loads for Anchor installed at 1-3/4 in. Edge Distance in Normal-Weight Concrete¹

Anchor Diameter in. (mm)	Minimum Depth Embedment in. (mm)	$f'_c = 2000$ psi (13.8 MPa)							
		Tension in. (mm)		Shear					
				Perpendicular to Edge in. (mm)		Parallel to Edge in. (mm)			
3/8 (9.5)	3 (76)	955 (4.2)	410 (1.8)	915 (4.1)					
1/2 (12.7)	3 (76)	930 (4.1)	375 (1.7)	1000 (4.4)					
	4-1/2 (114)	1285 (5.7)	445 (2.0)	1415 (6.3)					

1 Allowable loads based on safety factor of 4.0. Intermediate load values for other concrete strengths and embedments can be calculated by linear interpolation.

KWIK Bolt 3 Expansion Anchor 3.3.6

Table 15 - KWIK Bolt 3 Carbon Steel and Stainless Steel KWIK Bolt 3 Allowable Loads, installed into the Underside of Lightweight Concrete on Metal Profile Deck¹

Anchor Material	Anchor Diameter in. (mm)		Embedment Depth in. (mm)		$f'_c = 3000 \text{ psi (20.7 MPa)}$			
					Tension lb (kN)		Shear lb (kN)	
Carbon Steel	1/4	(6.4)	2	(51)	620	(2.8)	713	(3.2)
	3/8	(9.5)	2-1/2	(64)	1035	(4.6)	1370	(6.1)
	1/2	(12.7)	3-1/2	(89)	1725	(7.7)	2435	(10.8)
	5/8	(15.9)	4	(102)	2220	(9.9)	3160	(14.1)
Stainless Steel	1/4	(6.4)	2	(51)	615	(2.7)	650	(2.9)
	3/8	(9.5)	2-1/2	(64)	1015	(4.5)	1450	(6.4)
	1/2	(12.7)	3-1/2	(89)	1475	(6.6)	2200	(9.8)
	5/8	(15.9)	4	(102)	2220	(9.8)	3355	(14.9)

1 Allowable loads based on using a safety factor of 4.0.

Figure 3 - Installation in Concrete over Metal Deck

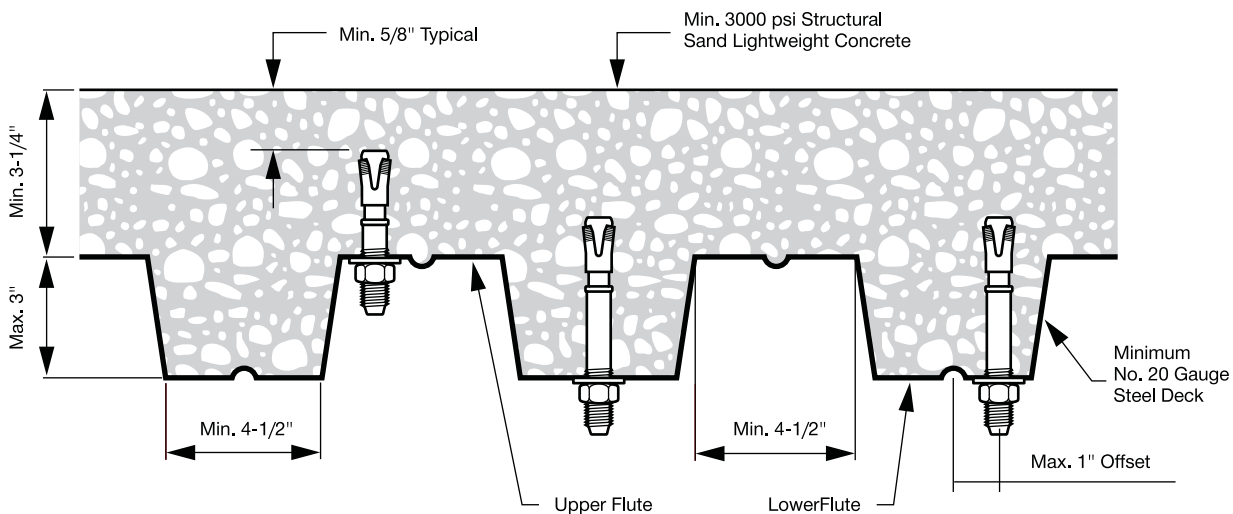

Table 16 - Countersunk KWIK Bolt Allowable Loads in Normal-Weight Concrete¹

Anchor Material	Anchor Diameter in. (mm)		Embedment Depth in. (mm)		$f'_c = 3000 \text{ psi (20.7 MPa)}$			
					Tension lb (kN)		Shear ² lb (kN)	
Carbon Steel	1/4	(6.4)	1-1/8	(29)	365	(1.6)	350	(1.6)
	3/8	(9.5)	1-5/8	(41)	810	(3.6)	750	(3.3)
Stainless Steel	1/4	(6.4)	1-1/8	(29)	320	(1.4)	500	(2.2)
	3/8	(9.5)	1-5/8	(41)	670	(3.0)	1330	(5.9)

1 Allowable loads based on using a safety factor of 4.0.

2 Shear values acting thru threads of anchor bolt. If acting through the empty shell, reduce loads by 70%.

3.3.6 KWIK Bolt 3 Expansion Anchor

Table 17 - Carbon Steel KWIK Bolt 3 Allowable Loads for Anchors Installed in Top of Grout-Filled Concrete Masonry Wall¹

Anchor Diameter in. (mm)	Embedment Depth in. (mm)	Tension lb (kN)	Shear	
			V ₁ lb (kN)	V ₂ lb (kN)
1/2 (12.7)	3 (76)	645 (2.9)	310 (1.4)	615 (2.7)
5/8 (15.9)	3-1/2 (89)	850 (3.8)	310 (1.4)	615 (2.7)

¹ Masonry prism strength must be at least 1500 psi at the time of installation in accordance with UBC Standard 21-17.

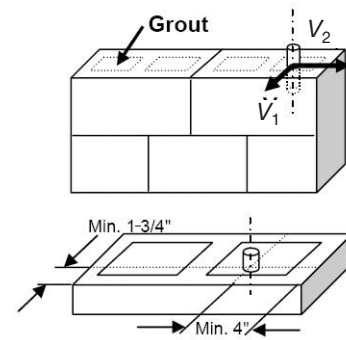

Table 18 - HHDCA Ceiling Hanger Allowable Loads¹

Anchor Diameter in. (mm)	Minimum Embedment in. (mm)	Normal Weight Concrete ²		Lightweight Concrete ³	Lightweight Concrete ³
		Tension lb (kN)	Shear lb (kN)	Tension lb (kN)	Shear lb (kN)
1/4 (6.4)	1-1/4 (32)	410 (1.8)	425 (1.9)	260 (1.2)	294 (1.3)

- ¹ Allowable loads based on using a safety factor of 4.0.
- ² Allowable loads are for anchors installed into normal-weight concrete having a minimum compressive strength of 3500 psi at the time of installation.
- ³ Allowable loads are for anchors installed into lightweight concrete having a minimum compressive strength of 3000 psi at the time of installation.

Combined Shear and Tension Loading

$$\left(\frac{N_d}{N_{rec}} \right)^{5/3} + \left(\frac{V_d}{V_{rec}} \right)^{5/3} \leq 1.0 \text{ (Ref. Section 3.1.8.3)}$$

Figure 4 - Installation in Grout-filled Concrete Masonry Unit

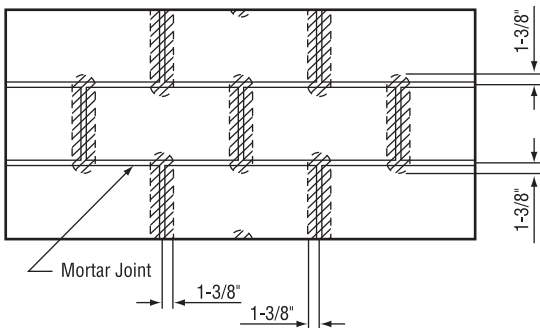

¹ Anchor installation is allowed in all non-shaded areas.

KWIK Bolt 3 Expansion Anchor 3.3.6

Table 19 - Carbon Steel KWIK Bolt 3 Allowable Loads in Grout-Filled Concrete Masonry Units^{1, 2, 3, 4, 5, 6}

Anchor Diameter in. (mm)	Anchor Depth in. (mm)	Minimum Distance from Edge of Block in. (mm)	Tension lb (kN)	Shear lb (kN)
1/4 (6.4)	1-1/8 (29)	4 (102)	150 (0.7)	380 (1.7)
		12 (305)		
	2 (51)	4 (102)	540 (2.4)	445 (2.0)
		12 (305)		
3/8 (9.5)	1-5/8 (41)	4 (102)	320 (1.4)	735 (3.3)
		12 (305)		
	2-1/2 (64)	4 (102)	780 (3.5)	1010 (4.5)
		12 (305)		
1/2 (12.7)	2-1/4 (57)	4 (102)	630 (2.8)	830 (3.7)
		12 (305)		
	3-1/2 (89)	4 (102)	905 (4.0)	1080 (4.8)
		12 (305)		
5/8 (15.9)	2-3/4 (70)	4 (102)	815 (3.6)	890 (4.0)
		12 (305)		
	4 (102)	4 (102)	1240 (5.5)	970 (4.3)
		12 (305)		
3/4 (19.1)	3-1/4 (83)	4 (102)	1035 (4.6)	785 (3.5)
		12 (305)		
	4-3/4 (121)	4 (102)	1645 (7.3)	825 (3.7)
		12 (305)		

- 1 Values are for anchors installed in Type 1 Grade N, lightweight, medium-weight, or normal-weight concrete masonry units conforming to UBC Standard 21-4. The masonry units must be fully grouted with coarse grout conforming to UBC Standard 21-15, Type S, N, or M. Masonry prism compressive strength must be at least 1500 psi at the time of installation when tested in accordance with UBC Standard 21-17.
- 2 Anchors must be installed a minimum of 1-3/8 inch from any vertical mortar joint (see figure).
- 3 Anchor locations are limited to one per masonry cell.
- 4 Embedment depth is measured from the outside face of the concrete masonry unit.
- 5 Linear interpolation to determine load values at intermediate edge distances is permitted.
- 6 All allowable loads based on safety factor of 4.0

Anchor Spacing and Edge Distance Guidelines

1. s = on-center fastening spacing
 c = edge distance from center of bolt.
2. Apply appropriate load reduction factors for tension and shear if anchor spacing and/or edge distance is less than the critical spacing (s_{cr}) or edge distance (c_{cr}).
3. See Section 3.1.8 for determining compounded spacing and edge distance reduction as well as intermediate load values for concrete strengths and embedments.

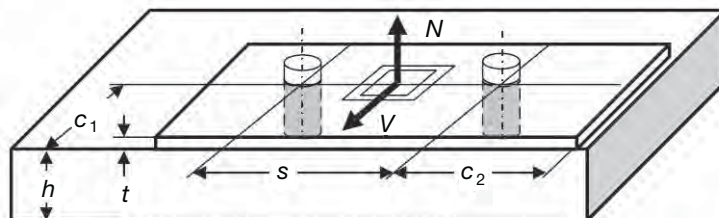

3.3.6 KWIK Bolt 3 Expansion Anchor

Edge Distance Adjustment Factors

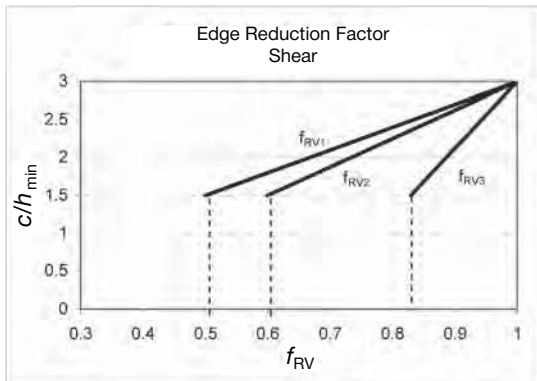
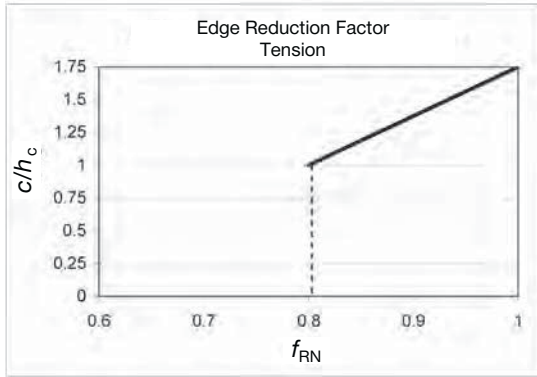

Adjustment Conditions	Critical Edge Distance	Minimum Edge Distance
Emb Ratio	$c/h_c = 1.75$	$c/h_c = 1.00$
Reduction	$f_{RN} = 1.00$	$f_{RN} = 0.80$
$h_c = h_{act}$		for $h_{min} \leq h_{act} \leq h_{nom}$
$h_c = h_{nom}$		for $h_{act} > h_{nom}$
h_{act} = Actual Embedment		
c = Actual Edge Distance		
f_{RN} = Edge Distance Reduction Factor for Tension Loading		

Shear Plane Correlation	Shear Conditions	f_{RV} Reduction factor at Min. Edge Distance
f_{RV1}	Shear towards edge	$f_{RV1} = 0.50$
f_{RV2}	Shear parallel edge	$f_{RV2} = 0.60$
f_{RV3}	Shear away from edge	$f_{RV3} = 0.83$
embedment to edge distance ratio at critical edge distance		$c/h_{min} = 3.00$
embedment to edge distance ratio at minimum edge distance		$c/h_{min} = 1.50$
c = Actual Edge Distance		
h_{min} = Min Embedment for Specific Anchor Diamete		

Anchor Spacing Adjustment Factors

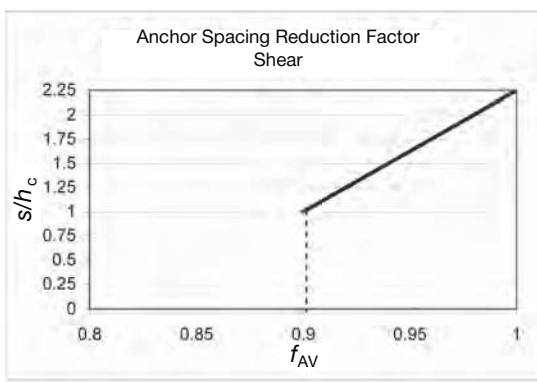
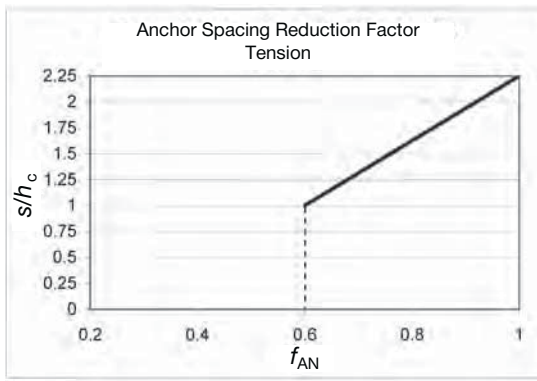

Adjustment Conditions	Critical Anchor Spacing	Minimum Anchor Spacing
Emb Ratio	$s/h_c = 2.25$	$s/h_c = 1.00$
Reduction	$f_{AN} = 1.00$	$f_{RN} = 0.60$
$h_c = h_{act}$		for $h_{min} \leq h_{act} \leq h_{nom}$
$h_c = h_{nom}$		for $h_{act} > h_{nom}$
h_{act} = Actual Embedment		
c = Actual Anchor Spacing Distance		
f_{AN} = Anchor Spacing Reduction Factor for Tension Loading		

Adjustment Conditions	Critical Anchor Spacing	Minimum Anchor Spacing
Emb Ratio	$s/h_c = 2.25$	$s/h_c = 1.00$
Reduction	$f_{AV} = 1.00$	$f_{AV} = 0.60$
$h_c = h_{act}$		for $h_{min} \leq h_{act} \leq h_{nom}$
$h_c = h_{nom}$		for $h_{act} > h_{nom}$
h_{act} = Actual Embedment		
c = Actual Anchor Spacing Distance		
f_{AV} = Anchor Spacing Reduction Factor for Shear Loading		

KWIK Bolt 3 Expansion Anchor 3.3.6

Influence of Edge Distance and Anchor Spacing on Anchor Performance

Load Adjustment Factors for 1/4" Diameter Anchors									
Adjustment Factor 1/4 in.	Spacing Tension f_{AN}		Edge Distance Tension f_{RN}		Spacing Shear f_{AV}		Edge Distance Shear		
							⊥ Toward Edge f_{RV1}	 Toward Edge f_{RV1}	⊥ Away from Edge f_{RV3}
Embedment Depth, in.	1-1/8	≥ 2	1-1/8	≥ 2	1-1/8	≥ 2	≥ 1-1/8	≥ 1-1/8	≥ 1-1/8
Spacing/Edge Distance, in.	1-1/8	0.60		0.80		0.90			
	1-11/16	0.75		0.93		0.94		0.50	0.60
	1-3/4	0.78		0.95		0.94		0.52	0.61
	2	0.85	0.60	1.00	0.80	0.96	0.90	0.59	0.67
	2-1/4	0.92	0.64		0.83	0.98	0.91	0.67	0.73
	2-1/2	0.99	0.68		0.87	1.00	0.92	0.74	0.79
	3	1.00	0.76		0.93		0.94	0.89	0.91
	3-3/8		0.82		0.98		0.96	1.00	1.00
	3-1/2		0.84		1.00		0.96	1.00	1.00
	4		0.92				0.98		
4-1/2		1.00				1.00			
4-3/4									
5									

Load Adjustment Factors for 3/8" Diameter Anchors									
Adjustment Factor 3/8 in.	Spacing Tension f_{AN}		Edge Distance Tension f_{RN}		Spacing Shear f_{AV}		Edge Distance Shear		
							⊥ Toward Edge f_{RV1}	 Toward Edge f_{RV1}	⊥ Away from Edge f_{RV3}
Embedment Depth, in.	1-5/8	≥ 2-1/2	1-5/8	≥ 2-1/2	1-5/8	≥ 2-1/2	≥ 1-5/8	≥ 1-5/8	≥ 1-5/8
Spacing/Edge Distance, in.	1-5/8	0.60		0.80		0.90			
	2	0.67		0.86		0.92			
	2-1/4	0.72		0.90		0.93			
	2-1/2	0.77	0.60	0.94	0.80	0.94	0.90	0.51	0.61
	3	0.87	0.66	1.00	0.85	0.97	0.92	0.62	0.69
	3-1/4	0.92	0.70		0.88	0.98	0.92	0.67	0.73
	3-1/2	0.97	0.73		0.91	0.99	0.93	0.72	0.77
	3-3/4	1.00	0.76		0.93	1.00	0.94	0.77	0.82
	4		0.79		0.96		0.95	0.82	0.86
	4-1/2		0.86		1.00		0.96	0.92	0.94
	5		0.92				0.98	1.00	1.00
	5-5/8		1.00				1.00		
	5-3/4								

Load Adjustment Factors for 1/2" Diameter Anchors									
Adjustment Factor 1/2 in.	Spacing Tension f_{AN}		Edge Distance Tension f_{RN}		Spacing Shear f_{AV}		Edge Distance Shear		
							⊥ Toward Edge f_{RV1}	 Toward Edge f_{RV1}	⊥ Away from Edge f_{RV3}
Embedment Depth, in.	2-1/4	≥ 3-1/2	2-1/4	≥ 3-1/2	2-1/4	≥ 3-1/2	≥ 2-1/4	≥ 2-1/4	≥ 2-1/4
Spacing/Edge Distance, in.	2-1/4	0.60		0.80		0.90			
	2-1/2	0.64		0.83		0.91			
	3	0.71		0.89		0.93			
	3-3/8	0.76		0.93		0.94		0.50	0.60
	3-3/4	0.81	0.62	0.98	0.82	0.95	0.91	0.56	0.64
	4-1/4	0.88	0.67	1.00	0.86	0.97	0.92	0.63	0.70
	4-3/4	0.96	0.71		0.90	0.99	0.93	0.70	0.76
	5	1.00	0.74		0.91	1.00	0.93	0.74	0.79
	5-3/4		0.81		0.97		0.95	0.85	0.88
	6		0.83		1.00		0.96	0.89	0.91
	6-1/2		0.87				0.97	0.96	0.97
	7-1/4		0.94				0.99	1.00	1.00
	7-3/4		1.00				1.00		

Standard Anchor Embedments (in.)		
1/4	h_{min}	1-1/8
	h_{nom}	2
	h_{deep}	3
3/8	h_{min}	1-5/8
	h_{nom}	2-1/2
	h_{deep}	3-1/2
1/2	h_{min}	2-1/4
	h_{nom}	3-1/2
	h_{deep}	4-3/4

Note: Tables apply for listed embedment depths. Reduction factors for other embedment depths must be calculated using equations below.

Spacing — Tension

$$f_{AN} = \frac{s/h_{act} + 0.88}{3.13} \quad h_{min} \leq h_{act} \leq h_{nom}$$

$$f_{AN} = \frac{s/h_{nom} + 0.88}{3.13} \quad h_{act} \geq h_{nom}$$

Edge Distance — Tension

$$f_{RN} = \frac{c/h_{act} + 2}{3.75} \quad h_{min} \leq h_{act} \leq h_{nom}$$

$$f_{RN} = \frac{c/h_{nom} + 2}{3.75} \quad h_{act} \geq h_{nom}$$

Spacing — Shear

$$f_{AV} = \frac{s/h_{act} + 10.25}{12.5} \quad h_{min} \leq h_{act} \leq h_{nom}$$

$$f_{AV} = \frac{s/h_{nom} + 10.25}{12.5} \quad h_{act} \geq h_{nom}$$

Edge Distance — Shear

$h_{act} \geq h_{min}$

perpendicular toward edge

$$f_{RV1} = \frac{c}{3h_{min}}$$

parallel to edge

$$f_{RV2} = \frac{c/h_{min} + 0.75}{3.75}$$

perpendicular away from edge

$$f_{RV3} = \frac{c/h_{min} + 5.82}{8.82}$$

Note: Edge distance and anchor spacing for all lightweight and sand-lightweight concrete are obtained by dividing the normal-weight dimensions by 0.75 and 0.85, respectively.

3.3.6 KWIK Bolt 3 Expansion Anchor

Influence of Edge Distance and Anchor Spacing on Anchor Performance

Load Adjustment Factors for 5/8" Diameter Anchors									
Adjustment Factor 5/8 in.	Spacing Tension f_{AN}		Edge Distance Tension f_{RN}		Spacing Shear f_{AV}		Edge Distance Shear		
							⊥	∥	⊥
							Toward Edge f_{RV1}	Toward Edge f_{RV1}	Away from Edge f_{RV3}
Embedment Depth, in.	2-3/4	≥ 4	2-3/4	≥ 4	2-3/4	≥ 4	≥ 2-3/4	≥ 2-3/4	≥ 2-3/4
Spacing/Edge Distance, in.	2-3/4	0.60	0.80		0.90				
	3-1/2	0.69	0.87		0.92				
	4	0.75	0.60	0.92	0.80	0.94	0.90		
	4-1/4	0.77	0.62	0.95	0.82	0.94	0.91	0.52	0.61
	4-3/4	0.83	0.66	1.00	0.85	0.96	0.92	0.58	0.66
	5-1/2	0.92	0.72		0.90	0.98	0.93	0.67	0.73
	6	0.98	0.76		0.93	0.99	0.94	0.73	0.78
	6-1/4	1.00	0.78		0.95	1.00	0.95	0.76	0.81
	7		0.84		1.00		0.96	0.85	0.88
	7-1/2		0.88				0.97	0.91	0.93
	7-3/4		0.90				0.98	0.94	0.95
	8-1/2		0.96				0.99	1.00	1.00
9		1.00							

Load Adjustment Factors for 3/4" Diameter Anchors									
Adjustment Factor 3/4 in.	Spacing Tension f_{AN}		Edge Distance Tension f_{RN}		Spacing Shear f_{AV}		Edge Distance Shear		
							⊥	∥	⊥
							Toward Edge f_{RV1}	Toward Edge f_{RV1}	Away from Edge f_{RV3}
Embedment Depth, in.	3-1/4	≥ 4-3/4	3-1/4	≥ 4-3/4	3-1/4	≥ 4-3/4	≥ 3-1/4	≥ 3-1/4	≥ 3-1/4
Spacing/Edge Distance, in.	3-3/8	0.61	0.81		0.90				
	4	0.67	0.86		0.92				
	5	0.77	0.62	0.94	0.81	0.94	0.90	0.51	0.61
	5-3/4	0.85	0.67	1.00	0.86	0.96	0.92	0.59	0.67
	6-1/4	0.90	0.70		0.88	0.97	0.93	0.64	0.71
	6-1/2	0.92	0.72		0.90	0.98	0.93	0.67	0.73
	7	0.97	0.75		0.93	0.99	0.94	0.72	0.77
	7-1/2	1.00	0.79		0.95	1.00	0.95	0.77	0.82
	8-1/4		0.84		1.00		0.96	0.85	0.88
	9		0.89				0.97	0.92	0.94
	9-3/4		0.94				0.98	1.00	1.00
	10-1/4		0.97				0.99		
10-3/4		1.00				1.00			

Load Adjustment Factors for 1" Diameter Anchors									
Adjustment Factor 1 in.	Spacing Tension f_{AN}		Edge Distance Tension f_{RN}		Spacing Shear f_{AV}		Edge Distance Shear		
							⊥	∥	⊥
							Toward Edge f_{RV1}	Toward Edge f_{RV1}	Away from Edge f_{RV3}
Embedment Depth, in.	4-1/2	≥ 6	4-1/2	≥ 6	4-1/2	≥ 6	≥ 4-1/2	≥ 4-1/2	≥ 4-1/2
Spacing/Edge Distance, in.	4-1/2	0.60	0.80		0.90				
	6	0.71	0.60	0.89	0.80	0.93	0.90		
	7	0.78	0.65	0.95	0.84	0.94	0.91	0.52	0.61
	8	0.85	0.71	1.00	0.89	0.96	0.93	0.59	0.67
	9	0.92	0.76		0.93	0.98	0.94	0.67	0.73
	9-3/4	0.97	0.80		0.97	0.99	0.95	0.72	0.78
	10-1/4	1.00	0.83		0.99	1.00	0.96	0.76	0.81
	11-1/4		0.88		1.00		0.97	0.83	0.87
	11-5/8		0.90				0.98	0.86	0.89
	12-1/2		0.95				0.99	0.93	0.94
	13		0.97				0.99	0.96	0.97
	13-1/2		1.00				1.00	1.00	1.00
	14-3/4								

Standard Anchor Embedments (in.)		
5/8	h_{min}	2-3/4
	h_{nom}	4
	h_{deep}	5-1/2
3/4	h_{min}	3-1/4
	h_{nom}	4-3/4
	h_{deep}	6-1/2 ¹
1	h_{min}	4-1/2
	h_{nom}	6
	h_{deep}	9

1. Embedment depth shown reflects embedment for carbon steel anchor, deep embedment depth for stainless steel anchor is 8 inch.

Note: Tables apply for listed embedment depths. Reduction factors for other embedment depths must be calculated using equations below.

Spacing — Tension	
$f_{AN} = \frac{s/h_{act} + 0.88}{3.13}$	$f_{AN} = \frac{s/h_{nom} + 0.88}{3.13}$

Edge Distance — Tension	
$f_{RN} = \frac{c/h_{act} + 2}{3.75}$	$f_{RN} = \frac{c/h_{nom} + 2}{3.75}$

Spacing — Shear	
$f_{AV} = \frac{s/h_{act} + 10.25}{12.5}$	$f_{AV} = \frac{s/h_{nom} + 10.25}{12.5}$

Edge Distance — Shear	
$h_{act} \geq h_{min}$	
perpendicular toward edge	
$f_{RV1} = \frac{c}{3h_{min}}$	
parallel to edge	
$f_{RV2} = \frac{c/h_{min} + 0.75}{3.75}$	
perpendicular away from edge	
$f_{RV3} = \frac{c/h_{min} + 5.82}{8.82}$	

Note: Edge distance and anchor spacing for all lightweight and sand-lightweight concrete are obtained by dividing the normal-weight dimensions by 0.75 and 0.85, respectively.

KWIK Bolt 3 Expansion Anchor 3.3.6

3.3.6.5 Installation Instructions

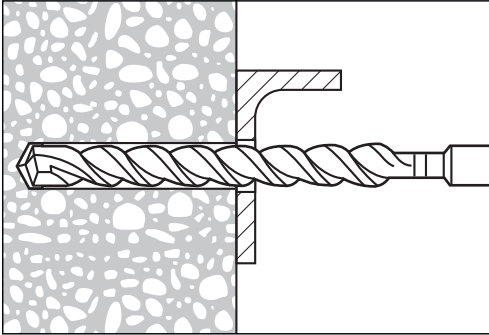

1. Hammer drill a hole to the same nominal diameter as the KWIK Bolt 3. The hole depth must exceed the anchor embedment by at least one diameter. The fixture may be used as a drilling template to ensure proper anchor location.

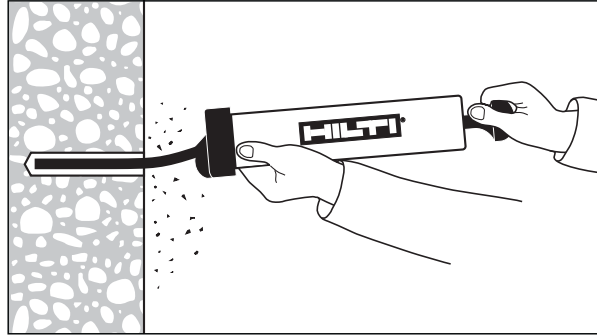

2. Clean hole.

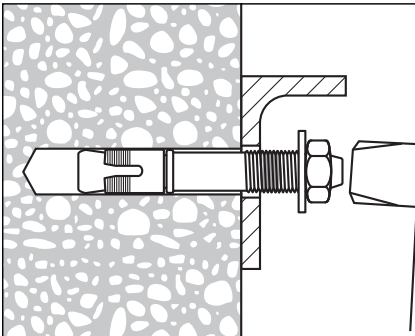

3. Drive the KWIK Bolt 3 into the hole using a hammer. The anchor must be driven until at least 6 threads are below the surface of the fixture.

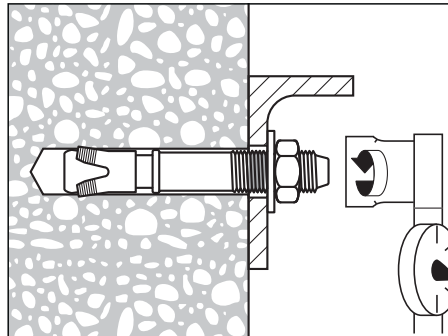

4. Tighten the nut to the installation torque.

3.3.6 KWIK Bolt 3 Expansion Anchor

Countersunk KWIK Bolt 3 Anchor Installation Instructions

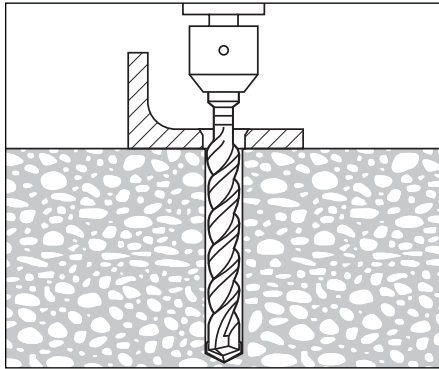

1. Drill.

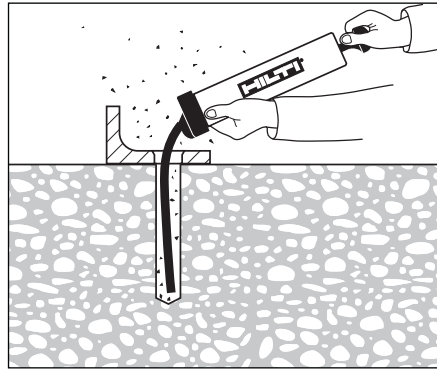

2. Clean.

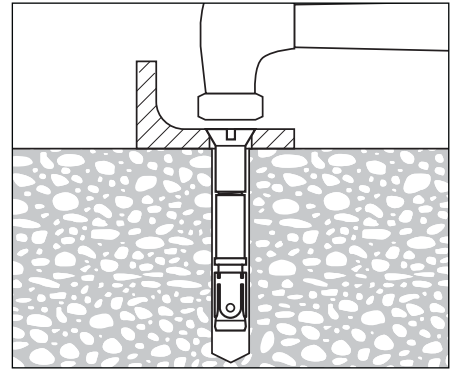

3. Thread post nut completely onto anchor. Tap into hole.

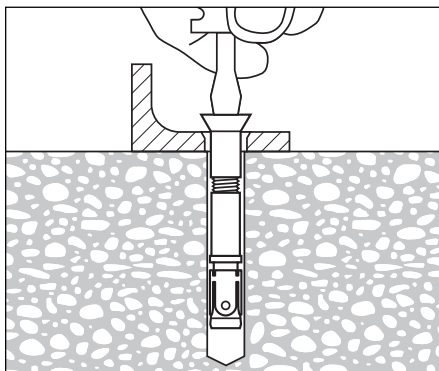

4. Loosen screw two full turns.

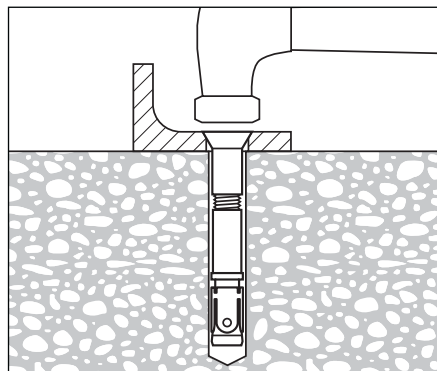

5. Tap-in again.

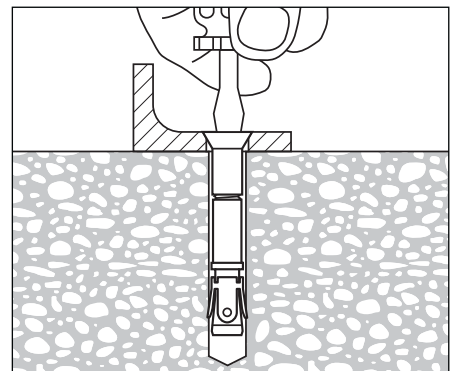

6. Tighten.

Rod Coupling KWIK Bolt 3 Anchor Installation Instructions

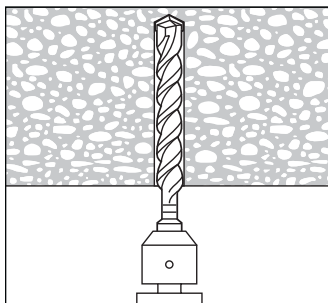

1. Drill.

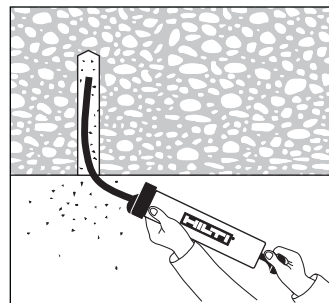

2. Clean.

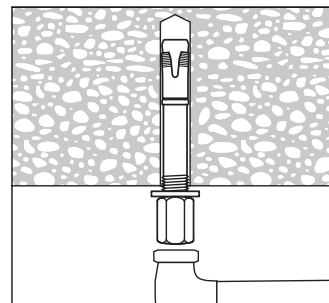

3. Tap-in.

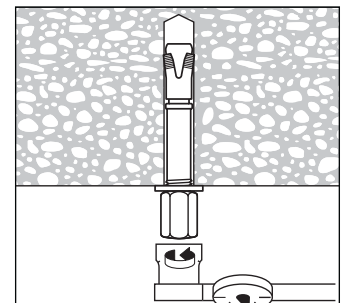

4. Tighten.

Hilti Ceiling KWIK Bolt (HDCA) Anchor Installation Instructions

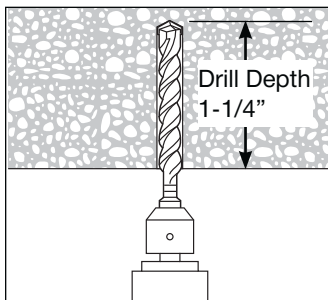

1. Drill hole using 1/4" bit.

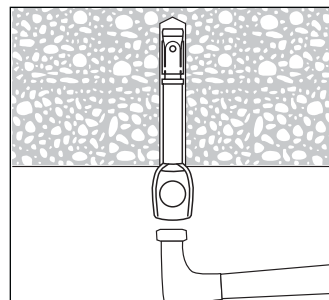

2. Tap in.

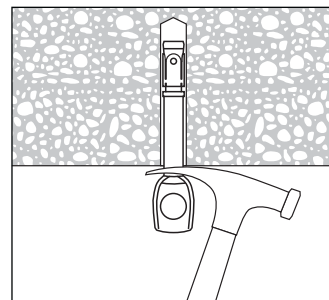

3. Pry downward.

KWIK Bolt 3 Expansion Anchor 3.3.6

3.3.6.6 Ordering Information

KWIK Bolt 3 Anchor Product Line

Size	Length (ℓ) in. (mm)	Thread Length (ℓ _{tr}) in. (mm)	ID Stamp	Box	Carbon Steel	304 SS	316 SS	HDG	
1/4 x 1-3/4	1-3/4 (44)	3/4 (18)	A	100	●	●			
1/4 x 2-1/4	2-1/4 (57)	7/8 (22)	B		●	●	●		
1/4 x 3-1/4	3-1/4 (83)	2 (51)	D		●	●			
		7/8 (22)					●		
1/4 x 4-1/2	4-1/2 (114)	2-7/8 (75)	G		●				
3/8 x 2-1/4	2-1/4 (57)	7/8 (22)	B	50	●	●			
3/8 x 3	3 (76)	1-1/4 (32)	D					●	
		1-1/2 (40)			●	●			
3/8 x 3-3/4	3-3/4 (95)	1-1/4 (32)	E					●	
		2-1/4 (59)			●	●			
3/8 x 5	5 (127)	3-1/2 (91)	H		●	●			
3/8 x 7	7 (178)	5-1/2 (142)	L		●	●			
1/2 x 2-3/4	2-3/4 (70)	1-1/4 (33)	C		25	●	●		
1/2 x 3-3/4	3-3/4 (95)	1-5/16 (35)	E					●	
		2-3/16 (56)		●		●		●	
1/2 x 4-1/2	4-1/2 (114)	1-5/16 (35)	G					●	
		2-7/8 (75)		●		●		●	
1/2 x 5-1/2	5-1/2 (140)	1-5/16 (35)	I					●	
		3-3/4 (96)		●		●		●	
1/2 x 7	7 (178)	4-3/4 (121)	L	●		●		●	
5/8 x 3-3/4	3-3/4 (95)	1-1/2 (41)	E	15	●	●	●		
5/8 x 4-3/4	4-3/4 (121)	1-1/2 (41)	G					●	
		2-3/4 (70)			●	●		●	
5/8 x 6	6 (152)	1-1/2 (41)	J					●	
		4 (102)			●	●		●	
5/8 x 7	7 (178)	4-3/4 (121)			●				
5/8 x 8-1/2	8-1/2 (216)	6-1/2 (166)	O		●	●			
5/8 x 10	10 (254)	7 (180)	R		●	●			
3/4 x 4-3/4	4-3/4 (121)	1-1/2 (41)	G	20		●	●		
		2-7/16 (62)		10	●			●	
				20		●			
3/4 x 5-1/2	5-1/2 (140)	1-1/2 (41)	I	20		●			
		3-7/16 (85)		10	●			●	
				20		●			
3/4 x 7	7 (178)	1-1/2 (41)	L			●			
		4-5/8 (119)		●					
3/4 x 8	8 (203)	5-3/4 (146)	N	10	●	●		●	
3/4 x 10	10 (254)	5-7/8 (152)	R		●	●	●		
3/4 x 12	12 (305)	5-7/8 (152)	T		●	●			
					●				
1 x 6	6 (152)	2-1/4 (57)	J	5	●	●	●		
1 x 9	9 (114)	2-1/4 (57)	P		●	●			
1 x 12	12 (114)	6 (152)	T		●	●			

3.3.6 KWIK Bolt 3 Expansion Anchor

Countersunk KWIK Bolt 3 Anchor Product Line

Size	Length in. (mm)	Box	Carbon Steel	304 SS
C1/4 x 2	2 (51)	100	•	
C1/4 x 3	3 (76)	100	•	•
C1/4 x 5	5 (127)	100	•	
C3/8 x 2-1/4	2-1/4 (57)	100	•	
C3/8 x 3	3 (76)	100	•	
C3/8 x 4	4 (102)	50	•	•
C3/8 x 5	5 (127)	50	•	

Rod Coupling KWIK Bolt 3 Anchor Product Line

Size	Length in. (mm)	Thread Length in. (mm)	ID Stamp	Box Quantity
3/8 x 2-1/4	2-1/4 (57)	7/8 (22)	B	100

HHDCA Ceiling Anchor Product Line

Size	Length in. (mm)	Eyelet Size in.	Box Quantity
1/4 x 2	2-1/32 (52)	5/16	100

KWIK Bolt 3 Anchor



Long Thread KWIK Bolt 3 Anchor

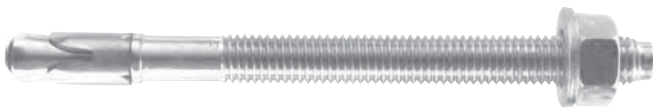

Countersunk KWIK Bolt 3 Anchor



Rod Coupling KWIK Bolt 3 Anchor (3/8" x 2 1/4" only)



HHDCA Ceiling Hanger (1/4" x 2" only)

