

UGMG

Plug

Class I, Div. 1 & 2, Groups B[Ⓢ], C, D
Class I, Zones 1 & 2, Groups IIB+H₂, IIA
Class II, Div. 1 & 2, Groups F, G
Class III
NEMA 3, 7 (B, C, D), 9 (F, G)

Listed File No. E91049 and/or E53660

Certified File No. LR14667

FEATURES-SPECIFICATIONS

ACCEPTOR®

The ACCEPTEUR® UGP/UGR Plug and Receptacle system, with its unique, patented design, is interchangeable[Ⓢ] with other NEMA bladed type explosion-proof and dust ignition proof devices. The series has been tested and classified for use with Crouse-Hinds® Ark-Gard^{®2} and Appleton® U-Line® plugs and receptacles in hazardous locations. **Now available in GFCI version. See page PR27.**

How The Acceptor System Works

ACCEPTEUR receptacles contain an integral switch which must be closed to energize the circuit. The design permits only an approved plug to be energized. To actuate the switch, the plug must be inserted and rotated clockwise approximately 45°. The plug will lock into this position preventing accidental disengagement. To remove, simply turn the plug counterclockwise and pull straight out.

Plugs and receptacles may be used where interchangeable bladed devices are needed in locations made hazardous by the presence of flammable gases or vapors, combustible dusts or easily ignitable fibers and flyings.

Plug can serve to provide power for portable equipment used in both hazardous and non-hazardous areas.

Applications

- Petroleum Refineries
- Chemical Plants
- Wet/Damp Areas
- Corrosive Environments
- Petroleum Plants
- Grain Elevators

- Flour and Feed Mills
- Indoor or Outdoor Locations

Features

- All external hardware is 316 stainless steel to provide low maintenance and long life
- Factory sealed chamber in UGR receptacle contains switch's arcing components
- No additional external seals are required, except in Group B applications

- Receptacles are U.L. Listed as raintight. Proper sealing against moisture is assured
- Spring loaded receptacle cover closes when plug is removed to provide protection when not in use
- Copper-free aluminum (less than 4/10 of 1%) alloy resists corrosion
- Electrostatically applied and baked powder epoxy/polyester finish

[Ⓢ] Exact models classified for interchangeability are listed in the information sheet provided with the products.

Ark-Gard[®] is a registered trademark of Crouse-Hinds[®].

U-Line[®] is a registered trademark of Appleton Electric Company[®].

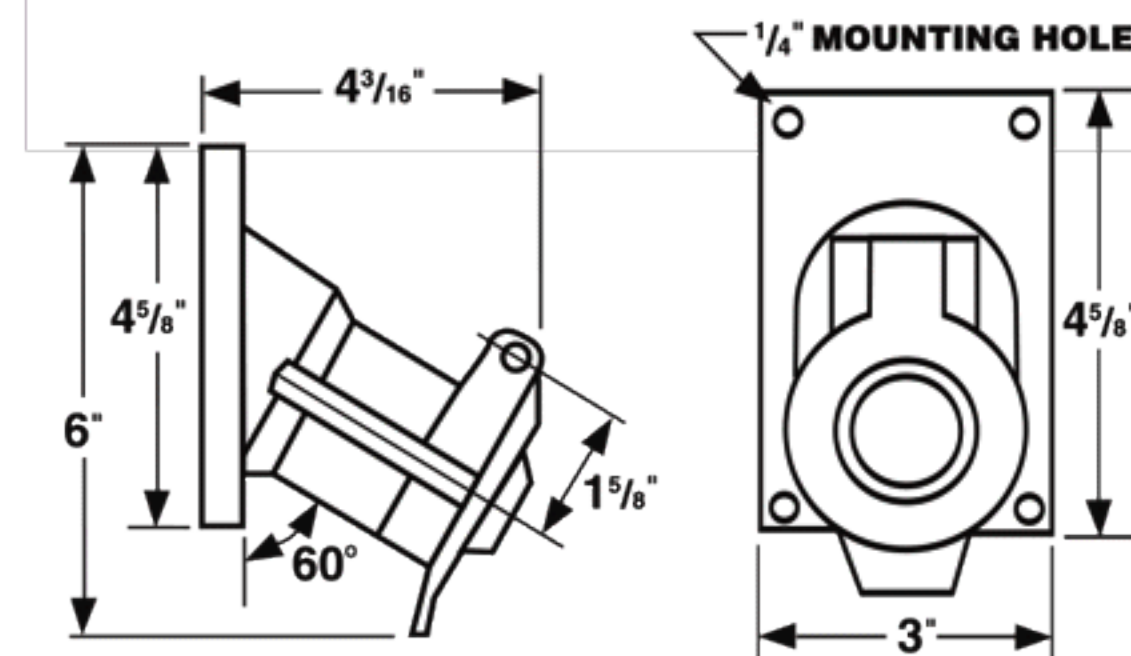

PLUG

ACCEPTEUR® plugs conform to NEMA configurations and can be used with standard receptacles in non-hazardous areas to maximize equipment utilization. The system's "turn to engage" feature

locks in plug and can be used to prevent accidental disengagement of critical equipment.

Plugs for use with type S, SO, ST or STO heavy duty cord.

VOLTAGE	NEMA CONFIGURATION	CATALOG NUMBER		NEMA CONFIGURATION	CATALOG NUMBER	
		15 AMP PLUG	15 AMP PLUG W/MESH GRIP		20 AMP PLUG	20 AMP PLUG W/MESH GRIP
125VAC	5-15P	UGP-15231	UGP-15231MG	5-20P	UGP-20231	UGP-20231MG
250VAC	6-15P	UGP-15232	UGP-15232MG	6-20P	UGP-20232	UGP-20232MG

[Ⓢ] Plugs Rated Group B when used with properly rated & installed receptacles. See next page.

Plugs with mesh grips (page PR26) are shipped as component plug and grip.

