

QTREN SERIES FAN/LIGHT/NIGHT LIGHTS MODELS QTREN090FLC & QTREN110FLC

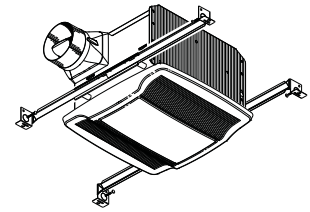

Ultra-quiet, high performance bath fan/light with a modern-styled grille.

FEATURES

BLOWER:

- Plug-in, permanently lubricated motor — engineered for continuous operation
- Dynamically balanced centrifugal blower wheel for quiet, efficient performance
- Low RPM for quiet operation
- Resilient anti-vibration motor mounts

HOUSING:

- Rugged, 26 gauge, galvanized steel construction
- Polymeric, 4" round duct connector with tapered sleeve and no metallic clatter
- 7 $\frac{5}{8}$ " height allows for 2" x 8" (nominal) joist installations
- Sturdy, easy, four-point mounting directly to joist
- Includes unique spacers (patent pending) for mounting to engineered "I"-joists
- Includes hanger bars to position housing anywhere between 16" to 24" on-center joists
- Two sets of mounting holes for hanger bars allow flush installation with bottom or top of drywall
- Can be mounted in ceilings up to 12/12 pitch

GRILLE:

- Polymeric construction
- Innovative design — the result of extensive research with designers and consumers
- Energy efficient lighting — uses (2) 18 W (max.) high efficiency, GU24 based, fluorescent lamps (included) and 4 W night light (not included)
- Durable steel reflector with white enamel finish

cULus Listed for use over bathtubs and showers when connected to a GFCI protected branch circuit (ceiling mount only).

cULus Listed for use in insulated ceilings (Type I.C.).

3-Year Warranty.

TYPICAL SPECIFICATION

Ceiling Ventilator shall be NuTone Model QTREN090FLC (QTREN110FLC).

Ceiling Ventilator shall have corrosion resistant galvanized steel housing with four-point mounting capability. It shall be ducted to a roof or wall cap using 4" round ductwork.

Blower assembly shall be removable, have a centrifugal-type blower wheel and a permanently lubricated motor designed for continuous operation and mounted with resilient anti-vibration mounts.

Non-metallic damper/duct connector shall be included.

Lamps shall be (2) 18 W (max.) high efficiency, GU24 based fluorescents with separate 4 W night light.

Air delivery shall be no less than 90 CFM (42.5 L/s), 110 CFM (51.9 L/s) and sound level no greater than 1.0 (1.3) sones. All air and sound ratings shall be certified by HVI.

Ceiling ventilator shall be ENERGY STAR® qualified and have an energy efficient permanent split capacitor motor.

Ceiling Ventilator shall be cULus Listed for use in insulated ceilings (Type I.C.) and for use over bathtubs and showers when connected to a GFCI protected branch circuit.



HVI-2100 CERTIFIED RATINGS comply with new testing technologies and procedures prescribed by the Home Ventilating Institute for off-the-shelf products, as they are available to consumers. Product performance is rated at 0.1 in. static pressure, based on tests conducted in AMCA's state-of-the-art test laboratory. Sones are a measure of humanly-perceived loudness, based on laboratory measurements.



Broan-NuTone Canada Inc., Mississauga, Ontario www.nutone.ca 877-896-1119

REFERENCE	QTY.	REMARKS	Project
			Location
			Architect
			Engineer
			Contractor
			Submitted by Date

PERFORMANCE RATINGS

QTREN SERIES

FAN/LIGHT/NIGHT LIGHTS

HVI PERFORMANCE

Model	Sones @ 0.1" (2.5 mm) SP	CFM (L/s) @ 0.1" (2.5 mm) SP	CFM (L/s) @ 0.25" (6.4 mm) SP
QTREN090FLC	1.0	90 (42.5 L/s)	68 (32.1 L/s)
QTREN110FLC	1.3	110 (51.9 L/s)	96 (45.3 L/s)

AMPS & WATTS

Model	Amps*	Watts Fan	Watts Fan/Light
QTREN090FLC	1.0	27	57
QTREN110FLC	1.1	37	67

*Total connected load.

WEIGHT

Model	Shipping Weight
QTREN090FLC	15.4 lb (7.0 kg)
QTREN110FLC	15.4 lb (7.0 kg)

AIR FLOW PERFORMANCE

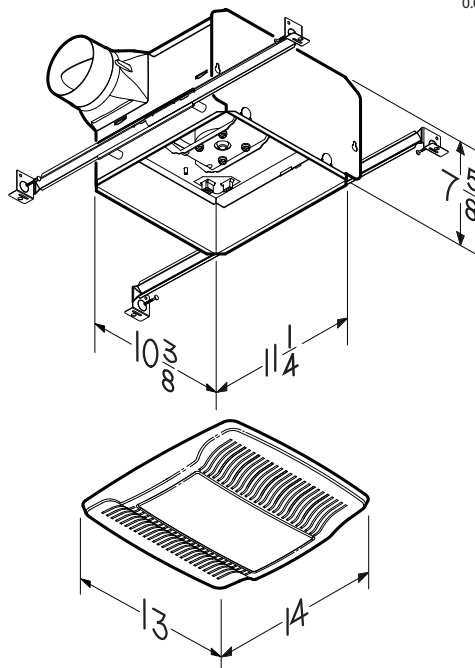
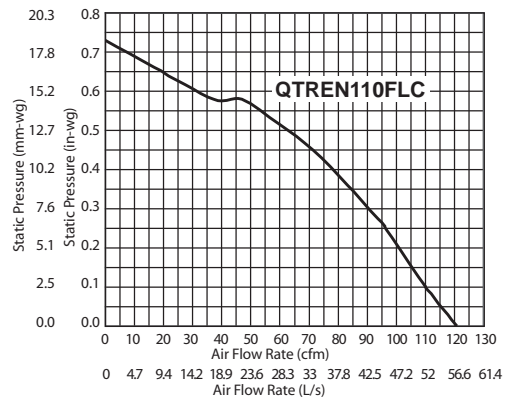
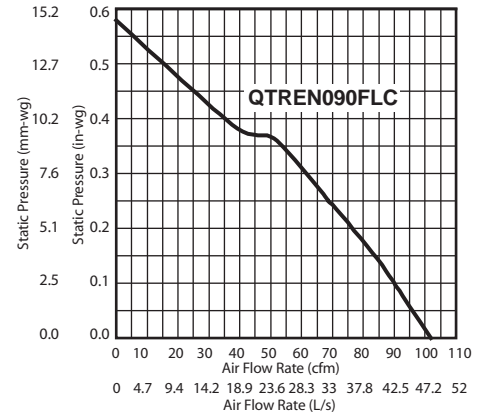

NOTE: Dimensions are in inches.

